



2019 Katalog

1984 yılında aile şirketi olarak kurulduk

22.500 m² alana kurulu üretim sahası

150 personel çalışanların %20'si mühendis ve teknisyen

86 çeşit testere makinası üretiyoruz

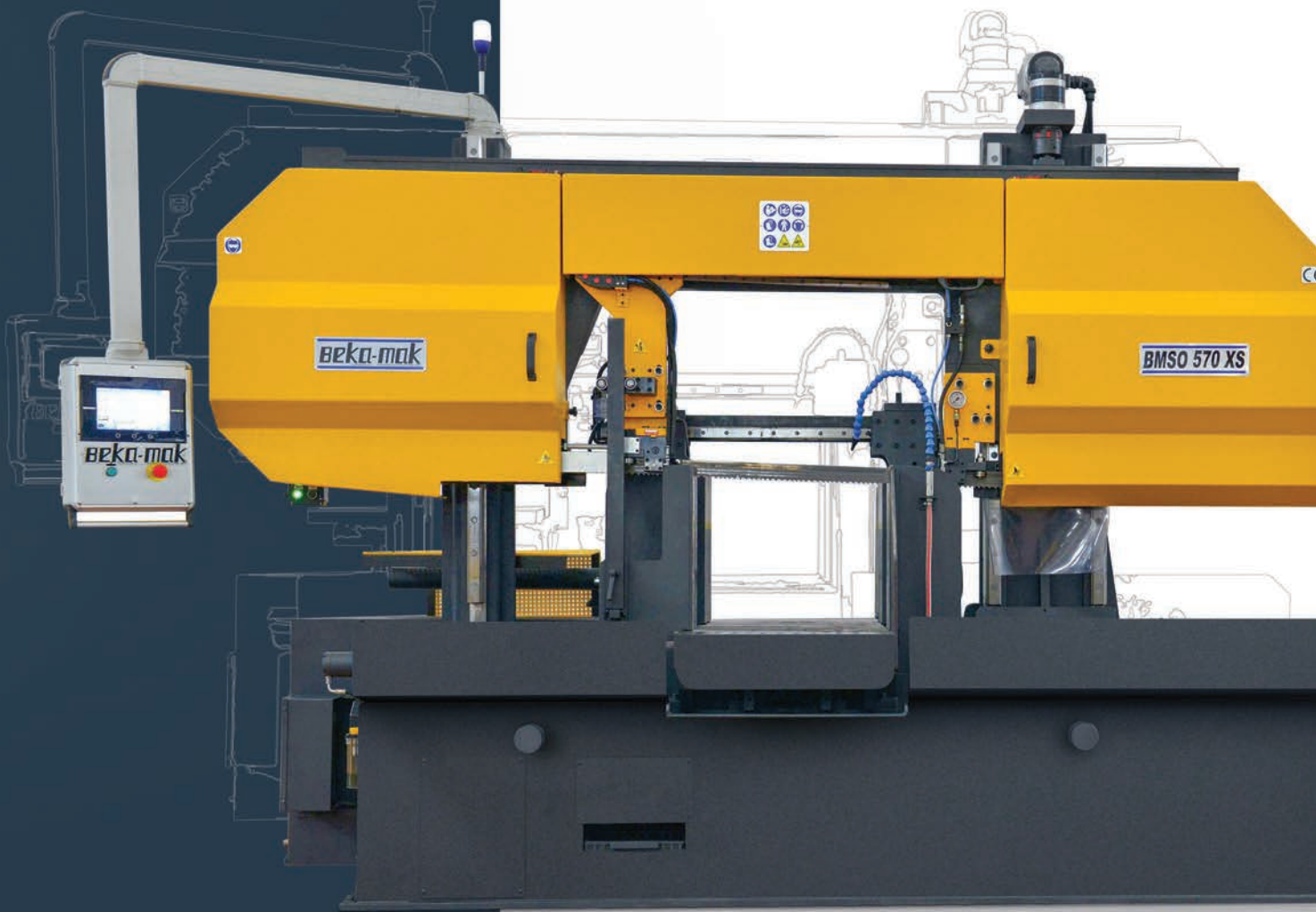

Her Şey Keserek Başlar

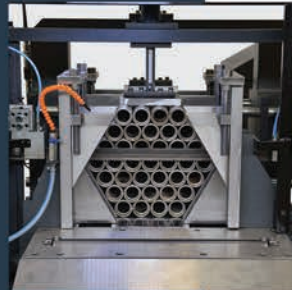

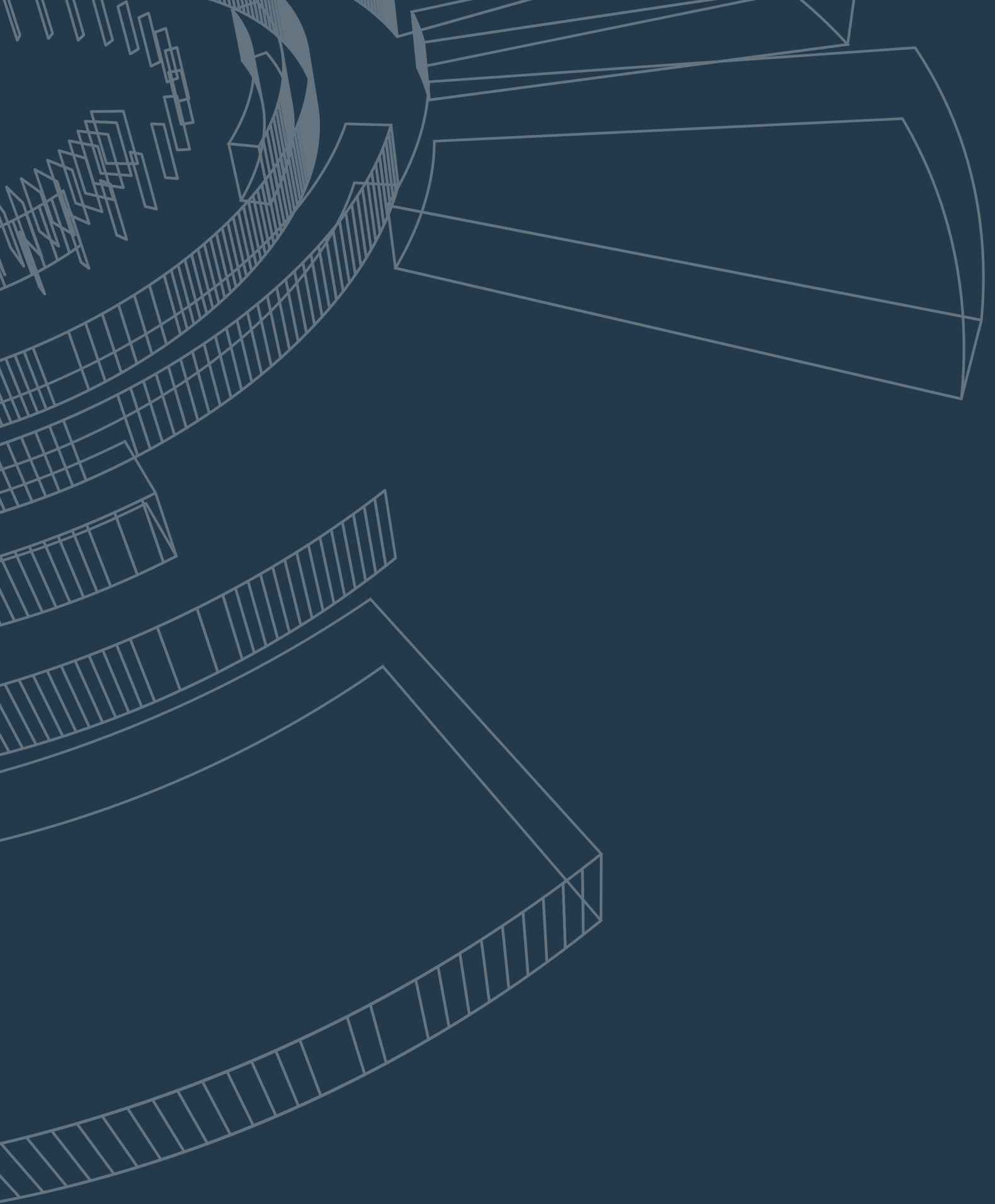



1984 yılında aile şirketi olarak kurulan Beka-Mak, Türkiye'de testere makinası sektörünü global pazara açan lider firmadır. İlk ihracatını Almanya'ya 1991 senesinde gerçekleştiren Beka-Mak, bugün başta Avrupa, Rusya ve A.B.D olmak üzere dünyada 60 distribütör tarafından 78'e yakın ülkede temsil edilmektedir. Geniş ürün yelpazesıyla yüksek verimde çalışan daire ve şerit testere makinalarımız, ülkemizin önde gelen çelik üreticilerinin de tercihleri olmaktadır.

Yenilikçi ve sürekli gelişim felsefesine sahip olan Beka-Mak, yeni kurulan tescilli Ar-Ge merkeziyle birlikte bugün 150 personel ile 22.500m² üretim alanında metal sektörüne katkıda bulunmaya devam ediyor.



Daire Testere Modelleri	BMDO ISAW - 100 IA	08
	BMDO ISAW - 120 IA	08
	BMDO ISAW - 150 IA	08
	BMDO ISAW - 80 VA	10



Otomatik Sürüclü Şerit Testere Modelleri	BMSO 570 XS	14
	BMSO 650 CS/CH NC	16
	BMSO 560 CS/CH NC	17
	BMSO 460 CS/CH NC	18
	BMSO 360 CS/CH NC	19
	BMSO 330 CS/CH NC	20
	P-SAW 330 CS	22



Otomatik Hidrolik Sürüclü Tek Taraf Açılı Şerit Testere Modelleri	BMSO 540 CGH/CGS NC	26
	BMSO 440 CGH/CGS NC	28
	BMSO 360 CGH/CGS NC	29
	BMSO 325 CGH/CGS NC	29
	BMSO 320 GH NC/GSL NC	30
	BMSO 320 GH NC/GS NC	31
	BMSO 320 H NC/S NC	32
	BMSO 320 LH NC/LS NC	33



Çift Tarafa Açılı Sütunlu Yarı Otomatik Şerit Testere Makina Modelleri	BMSY 650 DG NC	36
	BMSY 750 DG NC	37
	BMSY 560 DG	38
	BMSY 560 DG NC	38
	BMSY 440 CDGH	39
	BMSY 440 CDGH NC	39
	BMSY 360 CDGH	40



Ağır Tip Sütunlu Yarı Otomatik Şerit Testere Makina Modelleri	BMSY 1515C	44
	BMSY 1122C	46
	BMSY 1313C	48
	BMSY 1113C	50
	BMSY 1110C	51



Sütunlu Yarı Otomatik Şerit Testere Makina Modelleri	BMSY 1020C	54
	BMSY 820C	56
	BMSY 810C	58
	BMSY 650C	60
	BMSY 570C	61
	BMSY 560C	61
	BMSY 460C	62
	BMSY 360C	64
	BMSY 325C	65



Sütunlu Otomatik Şerit Testere Makina Modelleri	BMSO 820C	68
	BMSO 810C	70
	BMSO 560C	72
	BMSO 460C	73
	BMSO 360C	74
	BMSO 325C	75



Tek Taraf Açılı Şerit Testere Makina Modelleri

BMSY 810 CGH	78
BMSY 540 CGH	80
BMSY 440 CGH	82
BMSY 360 CGH	83
BMSY 325 CGH	84
BMSY 320 GL	85
BMSY 320 G	86
BMS 320 G	87



Çift Tarafa Açılı Mafsallı Şerit Testere Makina Modelleri

BMSY 440 DGH / DGH NC	90
BMSY 360 DGH	92
BMSY 360 DGH ECO	93
BMSY 270 DGH	94
BMSY 270 DG	94
BMS 270 DG	95
BMSY 230 DGH	96
BMSY 230 DG	96
BMS 230 DG	97



Mafsallı Otomatik Şerit Testere Makina Modelleri

BMSO 440	100
BMSO 320 L	101
BMSO 320	102
BMSO 230	103



Mafsallı Yarı Otomatik Şerit Testere Makina Modelleri

BMSY 440	106
BMSY 350 M	108
BMSY 320 L	109
BMSY 320	110
BMSY 280	111



MAFSALLI MANUEL ŞERİT TESTERE MAKİNASI

BMS 320	114
BMS 280	115



KOLLU TESTERE MAKİNASI

BMH 170	117
---------	-----



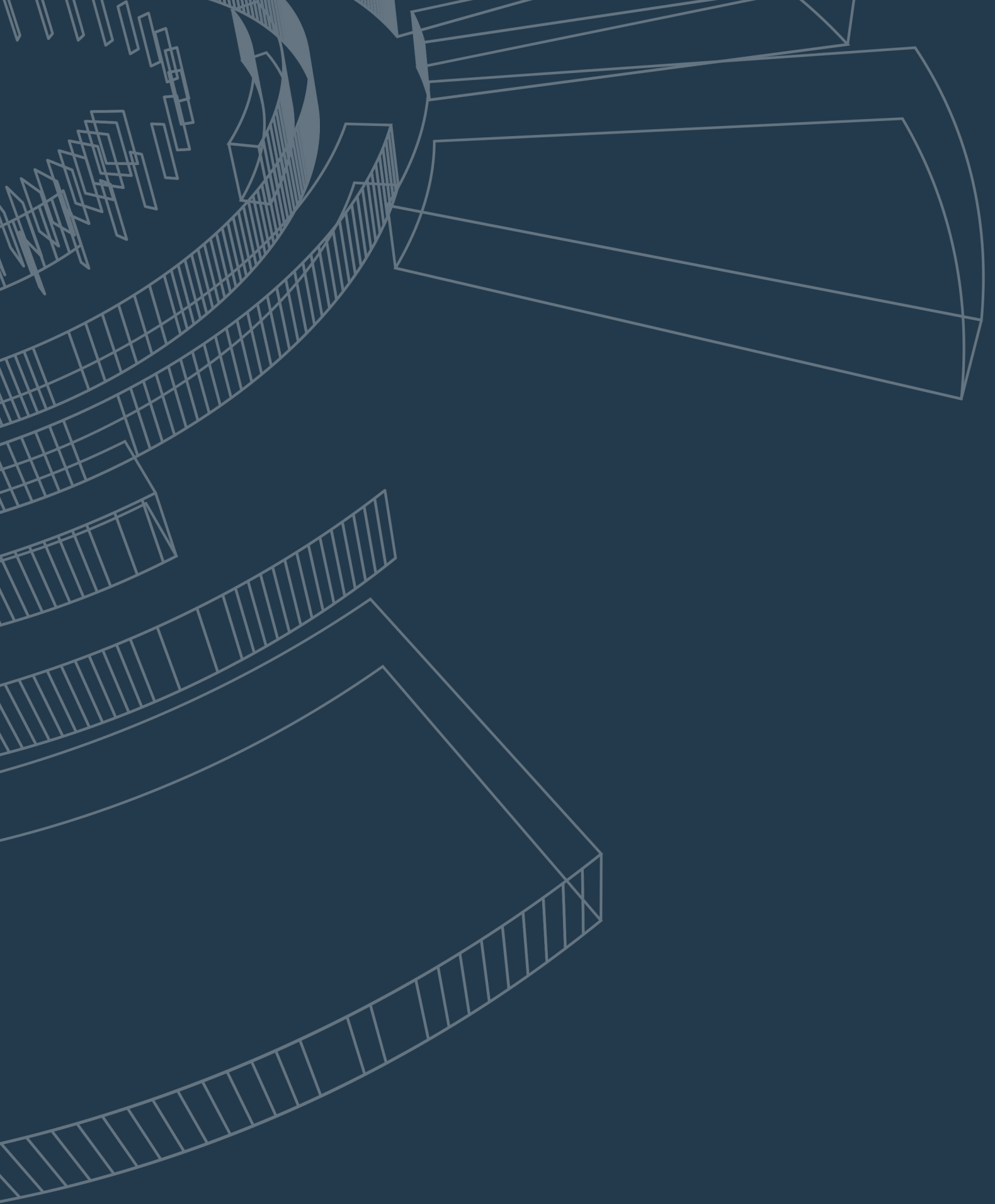

DAİRE TESTERE MODELLERİ

BMDO ISAW - 100 IA
BMDO ISAW - 120 IA
BMDO ISAW - 150 IA
BMDO ISAW - 80 VA



Model	Sayfa
BMDO ISAW 100 IA	08
BMDO ISAW 120 IA	08
BMDO ISAW 150 IA	08
BMDO ISAW 80 VA	10

BMDO ISAW - 100 IA

BMDO ISAW - 120 IA

BMDO ISAW - 150 VA

Tam Otomatik Daire Testere Makinası

BMDO XS SERİSİ, Dolu çelik ve demir dışı metallerin seri üretiminin gerektiği yerlerde hızlı kesim süresi ve kusursuza yakın malzeme yüzeyiyle müşterilerimizin beklentilerini karşılamaktadır. Elmas uçlu daire testere kullanımı için özel dizayn edilen BMDO XS serisi hızlı olduğu kadar sifıra yakın hassaslıkta da kesimler yapmaktadır. Bununla beraber istenildiği takdirde Yüksek Hız Çeliği (HSS) daire testere bıçağı kullanımı için de elverişlidir, bu sayede boru ve profil kesimleri de sağlanmaktadır. Standart olan 800mm servo besleme kursu ve 6 metrelik otomatik yükleme sehpasıyla yüksek ölçekli üretimler için idealdir.



Teknik Özellikler

	BMDO ISAW - 100 IA		BMDO ISAW - 120 IA		BMDO ISAW - 150 IA	
	∇	○	∇	○	∇	○
Kesme Kapasitesi	0°	20 - 100	0°	20 - 120	0°	20 - 150
Servo Besleme Kursu	800 mm		800 mm		800 mm	
Fire Boyu	60		60		60	
Magazin Boyu	6 m		6 m		6 m	
Magazin Ağırlığı	115 Kg		115 Kg		150 Kg	
Ana Motor	11 kW		15 kW		15 kW	
Hidrolik Motor	2,2 kW		4 kW		4 kW	
Soğutucu Motor	0,2 kW		0,2 kW		0,2 kW	
Sürücü Servo Motor	2 kW		2 kW		2 kW	
Kafa Servo Motor	2 kW		5 kW		5 kW	
Talaş Konveyör Motor	0,25 kW		0,25 kW		0,25 kW	
Kesme Hızları	40 - 200 m/min		40 - 280 m/min		40-280 m/min	
Testere Ölçüleri	Ø 360x2,6 mm		Ø 420 x 2,7 mm		Ø 460 x 2,7 mm	
Çalışma Yüksekliği	800 mm		800 mm		800 mm	
Ebatlar	Uzunluk 2460 mm Genişlik 2360mm	Yükseklik 2610 mm Ağırlık 3450 Kg	Uzunluk 2460 mm Genişlik 2450 mm	Yükseklik 2610 mm Ağırlık 3500 Kg	Uzunluk 2460 mm Genişlik 2450 mm	Yükseklik 2610 mm Genişlik 4000 Kg

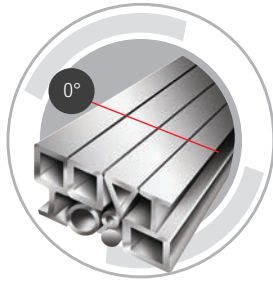

Maksimum Makina Performansı ve Uzun Çalışma İmkani İçin Mükemmel Redüktör Dizaynı

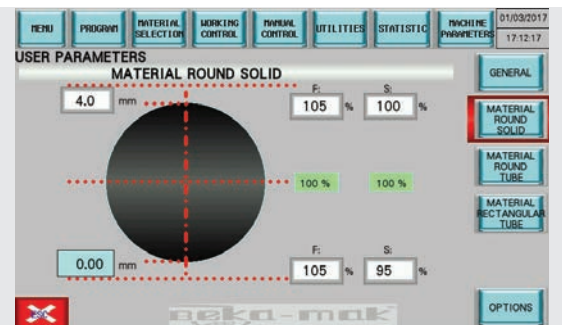



BMDO ISAW - 80 VA

Tam Otomatik Daire Testere Makinası

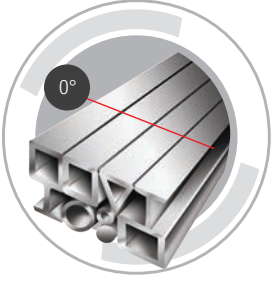
BMDO 80 VA- dikey kesme yönüyle boru kesiminde hızlı ve hassas olarak yüksek adetli kesim ihtiyaçlarını karşılamak için tasarlanmıştır. Yüksek Hız Çeliği(HSS) bıçak kullanımı için dizayn edilen BMDO 80CS, dolu kesimler için de müşterilerimizin beklentilerini karşılamaktadır. 500mm kurs servo beslemeli tam otomatik olan BMDO 80CS, çapaksız ve parlak yüzey bırakarak kesim yapar. Değişken kesim özelliğine sahip program malzemenin bıçak üzerine düşen alanına göre kesim hızını ayarlar ve kesim süresini minimuma indirir. Kesim sayısı yüklü miktarda olan müşterilerimize 6 metrelik otomatik yükleme sehpa opsiyonu ile operatör ihtiyacını minimuma indirme imkanı sağlamaktadır.



Teknik Özellikler

			Mengene Aıklığı	Besleme Kursu
Kesme Kapasitesi	0°	20 - 80	85 (max)	500 - 3000 max (One Stroke 500mm Multi Stroke 3000 mm)
Ana Motor	5,5 kW			
Hidrolik Motor	1,5 kW			
Soğutucu Motor	0,2 kW			
Sürücü Servo Motoru	1 kW			
Kafa Servo Motoru	2 kW			
Talaş Konveyör Motoru	0,25 kW			
Kesme Hızları	20 - 150 m/min			
Testere Ölçüleri HSS	Ø 280 ~ Ø350/2.0t ~ 3.0t (max) m/min			
Çalışma Yüksekliği	900 mm			
Ebatlar	Uzunluk 1600 mm	Genişlik 1700 mm	Yükseklik 2100 mm	Ağırlık 1425 kg

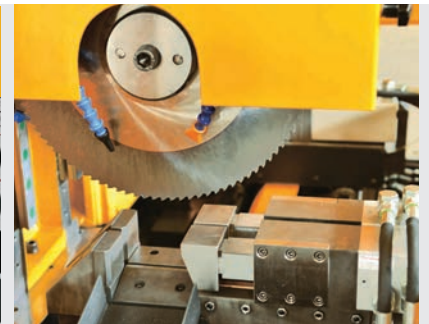
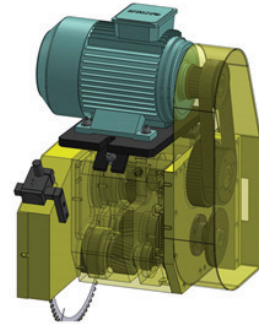

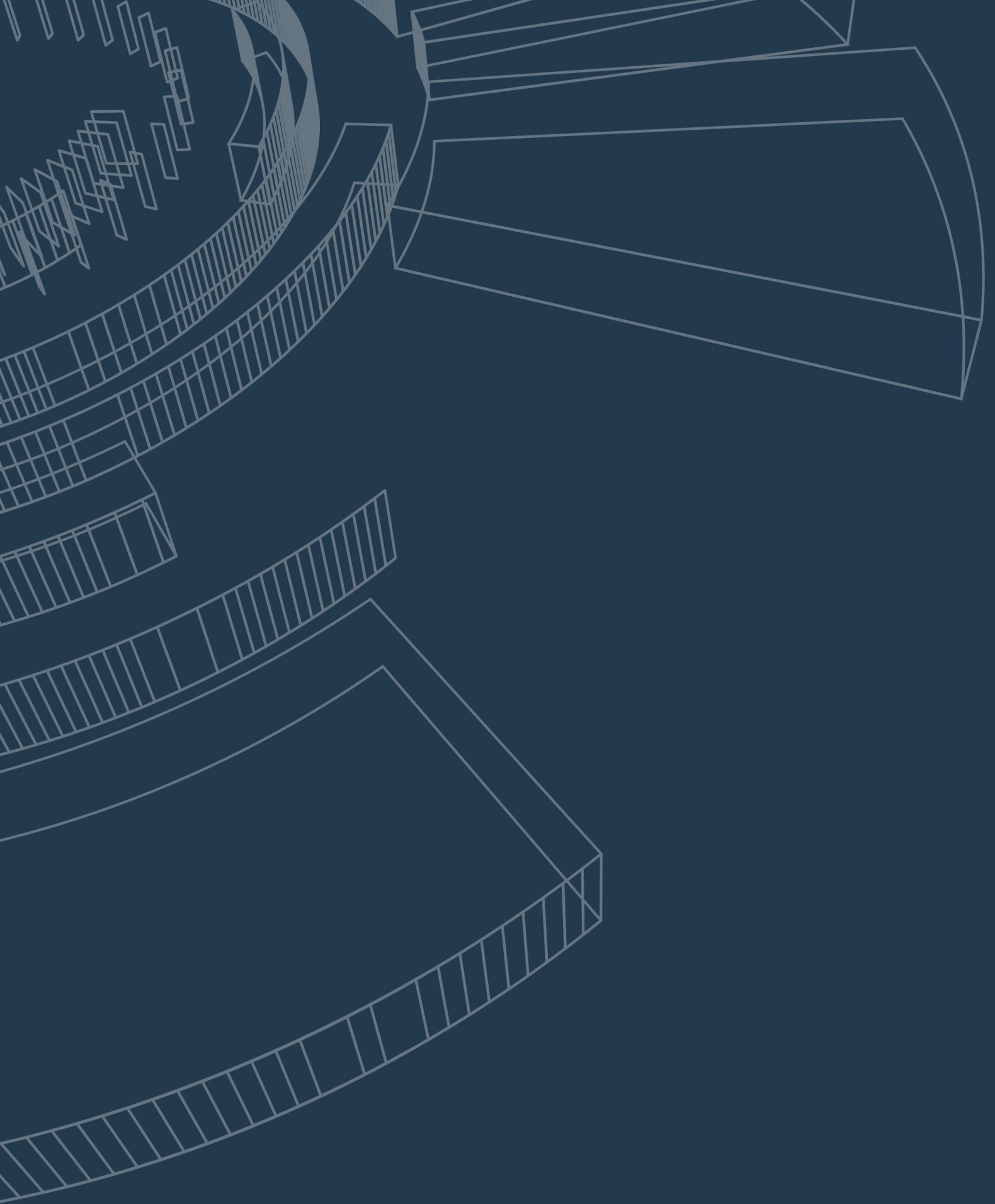

OTOMATİK SÜRÜCÜLÜ ŞERİT TESTERE MODELLERİ

**BMSO 570 XS - BMSO 650 CH/CS - BMSO 560 CH/CS
BMSO 460 CH/CS - BMSO 360 CH/CS NC
BMSO 330 CS/CH NC - P-SAW 330 CS**

XS Serisi

Kesim hızının ve bıçak ömrünün öneminin her geçen gün daha da önemli hale geldiği metal sektöründe, piyasaya XS serimizi duyurmaktan gurur duyuyoruz. Servo sürüş sistemiyle kesme boyu toleranslarında sıfır hata payını yakalayan makinalarımıza servo kesim sistemimiz ile CNC kesim özelliklerini de eklemiş bulunmaktayız. Akıllı kesim sistemine sahip XS serimiz malzeme cinsi ve ebatlarına göre optimum kesim parametrelerine karar vererek en verimli kesimi yapmaktadır. Titreşimler 3 lineer kızakla azaltılarak, güçlü platina gövde ve opsiyonlu 15kW motorla elmas uçlu testere kullanımı için de ideal olan XS bir şerit testere makinasından daha fazlasıdır.

CS Serisi

CS serisi sütunlu makinalardan oluşanservo sürücü sistemin entegrasyonu ile müşterilerimizin paket ve hassas uzunluktaki yüksek adetli kesim ihtiyaçlarını karşılayan ideal makinalarımızdır. Servo sürüş sistemi kesme boyu toleranslarını sıfır hata payına kadar indirmektedir. PLC kontrollü kullanıcı dostu ekran, 30 farklı programa 50 adımlı kesim emri girilmesine imkan sağlar. Hidrolik üst baskı ve aslanağzı opsiyonlarıyla da paket kesimler sağlar.

CH Serisi

Hidrolik sürücülü CH serimiz paket ve yüksek kesim adetleri için idealdir. PLC kontrol paneli 10 farklı adımlı kesimin programlanmasına imkan sağlar.

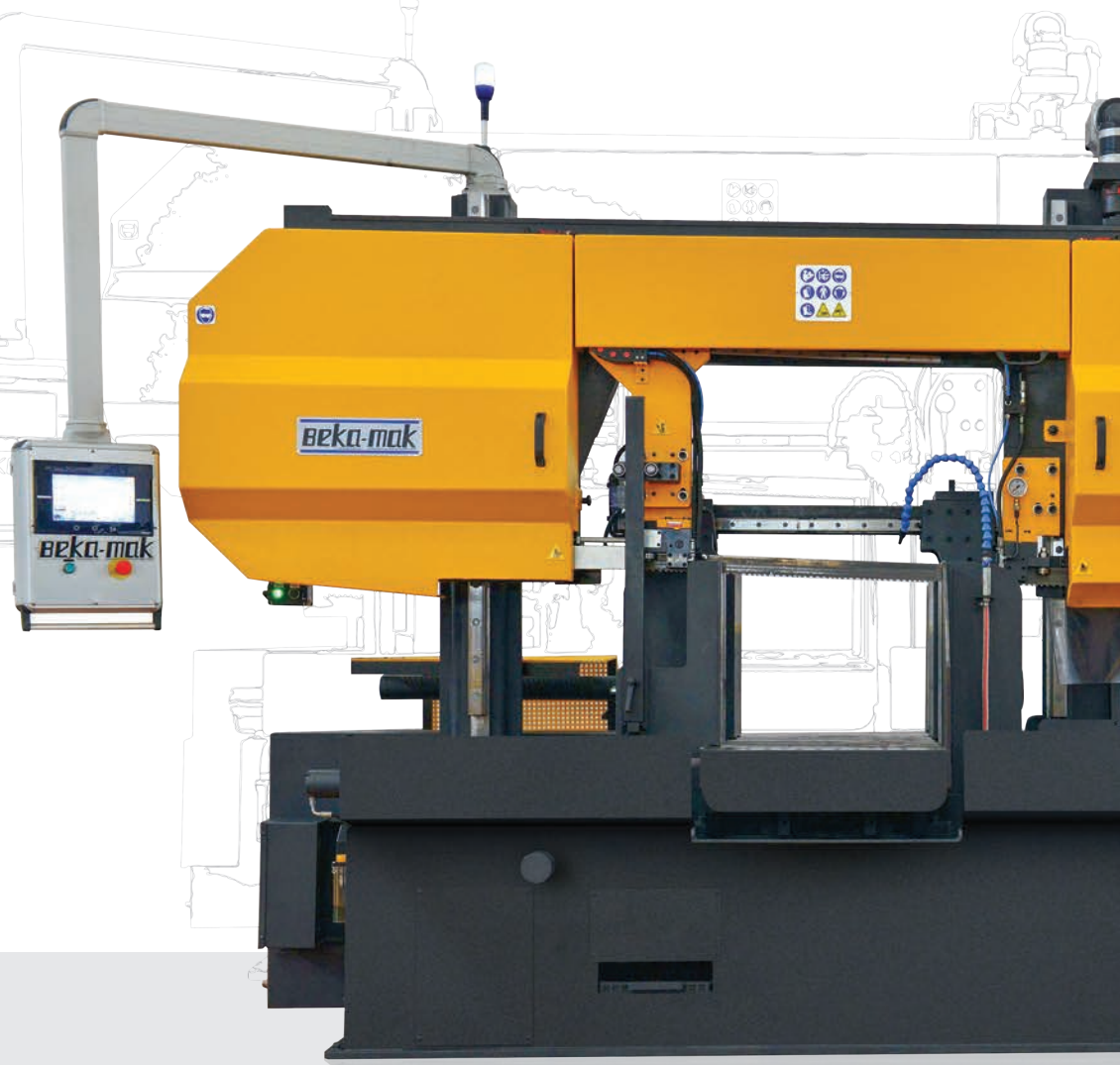

Model	Sayfa
BMSO 570 XS	14
BMSO 650 CS/CH	16
BMSO 560 CS/CH	17
BMSO 460 CS/CH NC	18
BMSO 360 CS/CH NC	19
BMSO 330 CS/CH NC	20
P-SAW 330 CS	22

BMSO 570 XS

Tam Otomatik Cnc Servo Kesim ve Servo Sürüclü Şerit Testere Makinası

Standartlar

Eğri Kesim Sensörü
Saplanma Kontrolü
Talaş Konveyoru
Hız Kontrol Cihazı
Optimum Kesim İçin Teknik Parametreleri
Kontrol Eden Cnc Akıllı Kesim
Hidrolik Kilitlemesi Ve Sıkma Çenesi
Senkronize Hareket Eden Kılavuz Kol
Hidrolik Elmas Yataklar
Manuel Kesim
Parametresi Girişi
Motorlu Talaş Fırçası
Led Lamba
Optikal Hızlı Yaklaşım
Hidrolik Şerit Germe
Kol Tipi Kumanda Paneli
Planet Redüktör

Opsiyonel

Hidrolik Üst Baskı
Mikrosprey Soğutucu
15 Kw Ana Motor
Aslan Ağızı Mengene

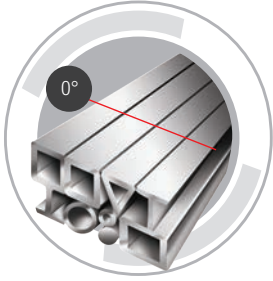

OPSİYONEL

Aslan Ağızı Mengene



Hidrolik Üst Baskı



Mikrosprey Soğutucu



15 kW Ana Motor



Teknik Özellikler

				
Kesme Kapasitesi	0°	570	600 x 570	570
Ana Motor	7,5 kW			
Hidrolik Motor	2,2 kW			
Soğutucu Motor	0,2 kW			
Talaş Konveyörü	0,37 kW			
Kafa İniş Servo Motor	1,5 kW			
Sürücü Servo Motor	2 kW			
Fırça Motoru	0,12 kW			
Kesme Hızları	20 - 100 m/min			
Kesme Hızları	(15 kW Motor) 20 - 150 m/min			
Sürücü Kurs Boyu	700 mm			
Opsiyonel Sürücü Kurs Boyu	1000 mm			
Maksimum Sürme Boyu	9999 mm			
Şerit Testere Ölçüsü	7400 x 54 x 1,6 mm			
Malzeme Besleme Yüksekliği	805 mm			
Ebatlar	Uzunluk 3500 mm	Genişlik 2000 mm	Yükseklik 2700 mm	Ağırlık 5900 kg

1 Endüstri 4.0 ile uyumlu yeni nesil PLC ve HMI altyapısı ile kullanıcı dostu ve esnek kullanım kolaylığı olan arayüz 50'ye kadar farklı boylarda kesim emri veren 100 farklı program kaydetme özelliği Malzeme cinsine göre kesim hızı hesaplanması

2 Hidrolik Şerit Germe Kontrolü

3 Servo iniş sistemi ile optimum kesim parametrelerini kontrol eden CNC akıllı kesim

4 Sapma Sensörü

5 Servo Sürüş Sistemi

1



2



3



4



5



BMSO 650 CS/CH NC - BMSO 560 CS/CH NC

CH Tam Otomatik Hidrolik Sürüclü Şerit Testere Makinası

CS Tam Otomatik Servo Sürüclü Şerit Testere Makinası

Standartlar

Kullanıcı Dostu Plc Kontrollü Ekran
Hidromekanik Şerit Germe
Talaş Fırçası
Lineer Kızaklı Üst Gövde
Optik Yükseklik Ayar Sensörü
Planet Redüktör
Hız Kontrol Cihazı
Hassas Kesim Ayarı
Saplanma Sensörü
Hidrolik Split Mengene
Talaş Konveyörü
Hidrolik Şerit Germe (650 CH/CS)

Opsiyonel

Hidrolik Şerit Germe
Paket Kesim Mengeneri
Mikrosprey Soğutucu
3 Metre Malzeme Sehpa
Hidrolik Üst Baskı
15 kW Ana Motor (BMSO 650 CS/CH)

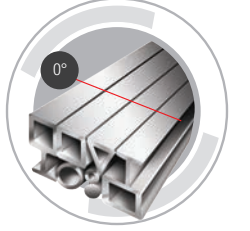
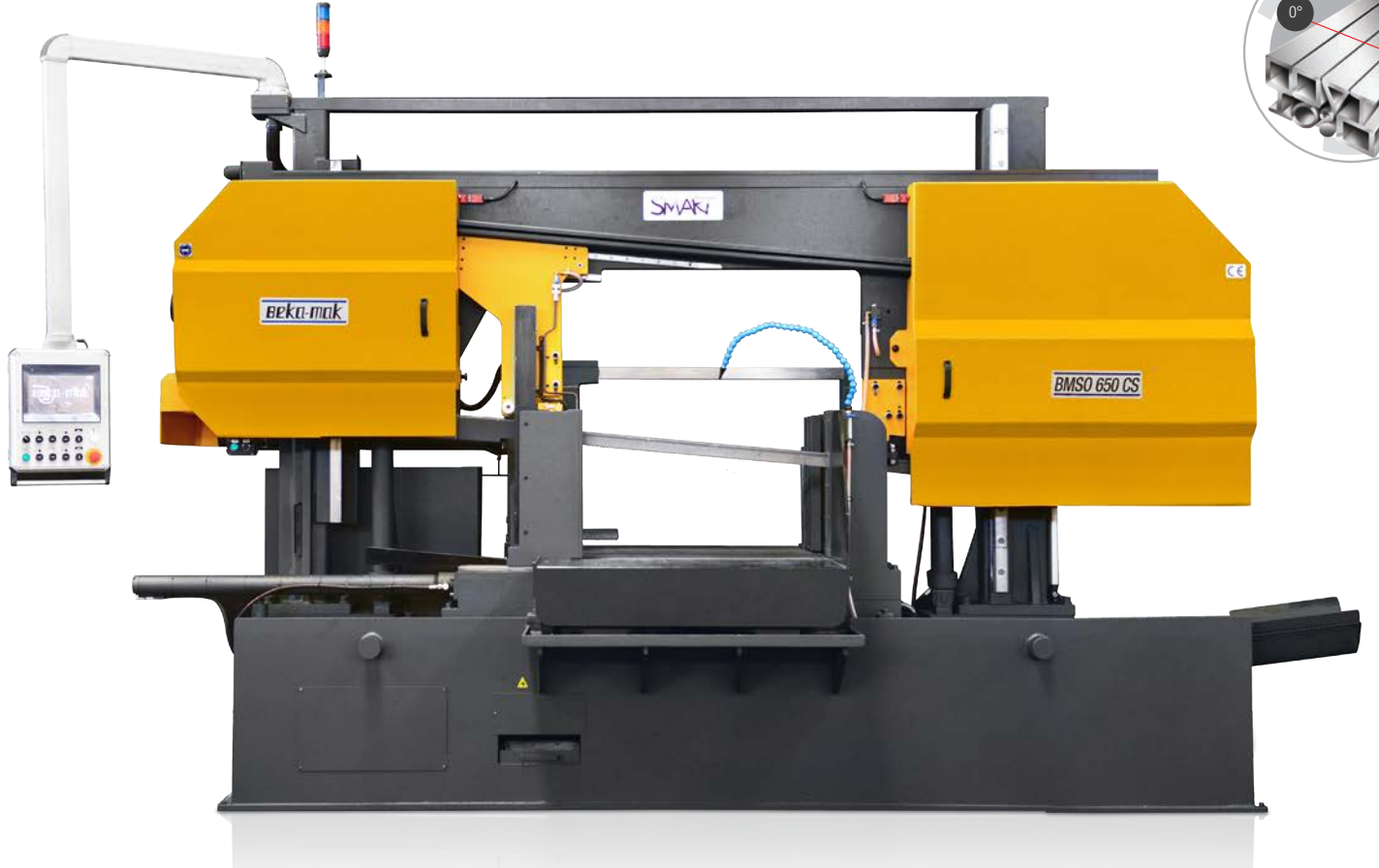

OPSIYONEL

Motorlu Talaş Fırçası



Hidrolik Şerit Germe



Paket Kesim Mengeneri



ILC Mikrosprey Soğutucu



3 Metre Malzeme Sehpa





Hidrolik Üst Baskı



Teknik Özellikler

BMSO 650 CS/CH NC

BMSO 560 CS/CH NC

								
Kesme Kapasitesi	0°	650	1050 x 600	600	0°	560	600 x 560	560
Ana Motor	7,5 kW				4 kW			
Hidrolik Motor	4 kW				2,2 kW			
Soğutucu Motor	0,12 kW				0,12 kW			
Sürücü Servo Motor (CS)	2 kW				2 kW			
Kesme Hızları	20 - 120 m/min				20 - 100 m/min			
Sürücü Kurs Boyu	700 mm (CS) - 500 mm (CH)				700 mm (CS) - 500 mm (CH)			
Maksimum Sürme Boyu	9999 mm (CS) - 6000 mm (CH)				9999 mm (CS) - 6000 mm (CH)			
Şerit Testere Ölçüsü	8400 x 54 x 1,6 mm				6000 x 41 x 1,3			
Malzeme Besleme Yüksekliği	825 mm				810 mm			
Ebatlar	Uzunluk 4250 mm Genişlik 1750 mm		Yükseklik 2600 mm Ağırlık 6580 kg		Uzunluk 3250 mm Genişlik 2200 mm		Yükseklik 2350 mm Ağırlık 4850 kg	

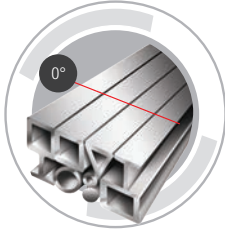

Talaş Konveyörü



Hidrolik Şerit Germe



Paket Kesim Mngeneleri



ILC Mikrosprey Soğutucu



3 Metre Malzeme Sehpaı



Hidrolik Üst Baskı



BMSO 460 CS/CH NC - BMSO 360 CS/CH NC

CH *Tam Otomatik Hidrolik Sürüclü Şerit Testere Makinası*

CS *Tam Otomatik Servo Sürüclü Şerit Testere Makinası*



Motorlu Talaş Fırçası



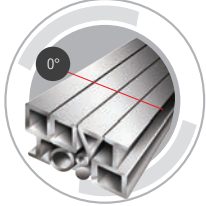

Teknik Özellikler

	BMSO 460 CS/CH NC				BMSO 360 CS/CH NC			
								
Kesme Kapasitesi	0°	460	550 x 460	460	0°	360	400 x 360	360
Ana Motor	4 kW				3 kW			
Hidrolik Motor	2,2 kW				1,5 kW			
Soğutucu Motor	0,12 kW				0,12 kW			
Sürücü Servo Motor	1 kW				1 kW			
Kesme Hızları	20 - 100 m/min				20 - 100 m/min			
Sürücü Kurs Boyu	700 mm (CS) - 500 mm (CH)				700 mm (CS) - 500 mm (CH)			
Maksimum Sürme Boyu	9999 mm (CS) - 6000 mm (CH)				9999 mm (CS) - 6000 mm (CH)			
Opsiyonel Sürücü Kurs Boyu	1000 mm				1000 mm			
Şerit Testere Ölçüsü	5200 x 41 x 1,3 mm				4800 x 34 x 1,1 mm			
Malzeme Besleme Yüksekliği	805 mm				800 mm			
Ebatlar	Uzunluk 3000 mm Genişlik 2100 mm		Yükseklik 2100 mm Ağırlık 3250 kg		Lenght 2850 mm Genişlik 2000 mm		Yükseklik 1890 mm Ağırlık 2580 kg	

Standartlar

Kullanıcı Dostu Plc Kontrollü Ekran
Hidromekanik Şerit Germe
Talaş Fırçası
Lineer Kızaklı Üst Gövde
Optik Yükseklik Ayar Sensörü
Planet Redüktör
Hız Kontrol Cihazı
Hassas Kesim Ayarı
Hidrolik Split Mengene

Talaş Konveyörü
Kesim Genişlik Ayar Kolu
Kapak Swich
Hassas Basınç Ayarı
Sap Boryağ pompası
Şerit Testere Bıçağı 41
Şerit Sıkışmasında Koruma Swich
Saplanma Sensörü

Opsiyonel

Hidrolik Şerit Germe
Paket Kesim Mengeneri
Mikrosprey Soğutucu
3 Metre Malzeme Sehpa
Hidrolik Üst Baskı
2° Eğik Kafa
Motorlu Talaş Fırçası

Hidrolik Şerit Germe

Paket Kesim
Mengeneri

Mikrosprey Soğutucu

3 Mt Malzeme Sehpa

Hidrolik Üst Baskı

2° Eğik Kafa

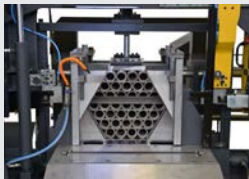

BMSO 330 CS/CH NC

CH *Tam Otomatik Hidrolik Sürüclü Şerit Testere Makinası*

CS *Tam Otomatik Servo Sürüclü Şerit Testere Makinası*

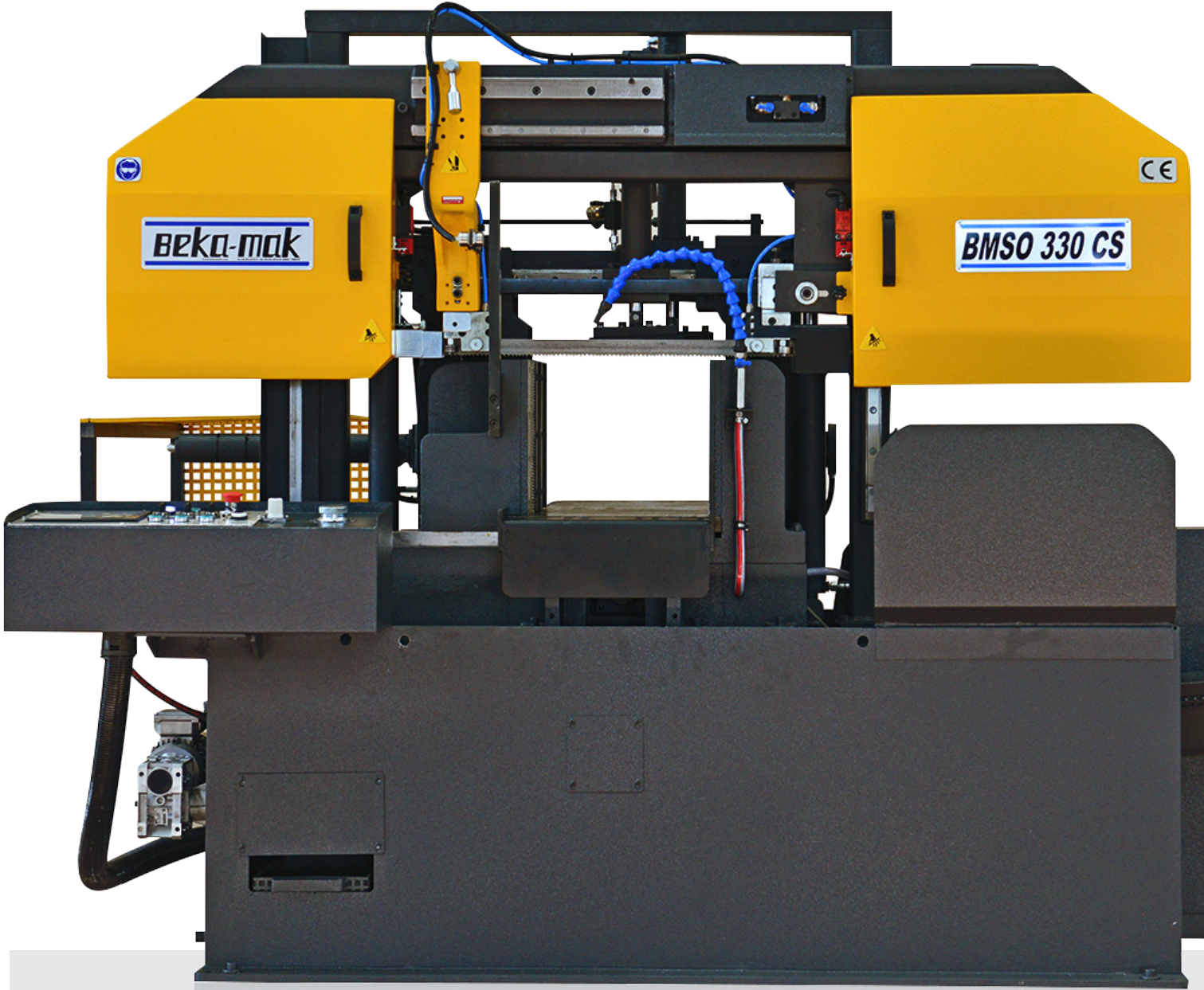

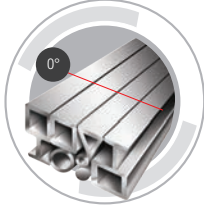

Teknik Özellikler

				
Kesme Kapasitesi	0°	330	360 x 330	330
Ana Motor	3 kW			
Hidrolik Motor	1,5 kW			
Soğutucu Motor	0,12 kW			
Sürücü Servo Motor	1 kW			
Kesme Hızları	20 - 100 m/min			
Maksimum Sürme Boyu	9999 mm			
Şerit Testere Ölçüsü	4380 x 34 x 1,1 mm			
Malzeme Besleme Yüksekliği	850			
Ebatlar	Uzunluk 2100 mm Genişlik 2300 mm Yükseklik 1560 mm Ağırlık 2120 kg			

Standartlar

Kullanıcı Dostu Plc Kontrollü Ekran
Hidromekanik Şerit Germe
Talaş Fırçası
Lineer Kızaklı Üst Gövde
Optik Yükseklik Ayar Sensörü
Planet Redüktör
Hız Kontrol Cihazı
Hassas Kesim Ayarı
Saplanma Sensörü
Hidrolik Split Mengene
Talaş Konveyörü

Opsiyonel

Hidrolik Şerit Germe
Paket Kesim Mengeneri
Mikrosprey Soğutucu
3 Metre Malzeme Sehpası
Hidrolik Üst Baskı
4 kW Motor

Motorlu Talaş Fırçası



Hidrolik Şerit Germe



Paket Kesim Mengeneri



Mikrosprey Soğutucu



3 Metre Malzeme Sehpası



Hidrolik Üst Baskı



P-SAW 330 CS

Tam Otomatik Servo Sürüclü Kabinli Şerit Testere Makinası

Standartlar

Hassas Basınç
Hidrolik Şerit Germe
Optik Yükseklik Ayar Sensörü
Servo Besleme
Talaş Konveyör



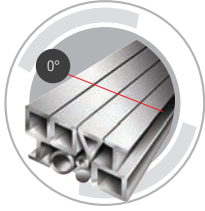

Opsiyonel

Aslanağzı Mengene
Mikrosprey Soğutucu
3 Mt. Malzeme Sehpası
Hidrolik Üst Baskı





Teknik Özellikler

				
Kesme Kapasitesi	0°	330	360 x 330	330
Ana Motor	3 kW			
Hidrolik Motor	1,5 kW			
Soğutucu Motor	0,12 kW			
Sürücü Servo Motor	0,25 kW			
Kesme Hızları	20 - 100 m/min			
Maksimum Sürme Boyu	700 mm			
Şerit Testere Ölçüsü	4380 x 34 x 1,1 mm			
Malzeme Besleme Yüksekliği	850			
Ebatlar	Uzunluk 2625 mm Genişlik 1900 mm Yükseklik 1900 mm Ağırlık 2150 kg			

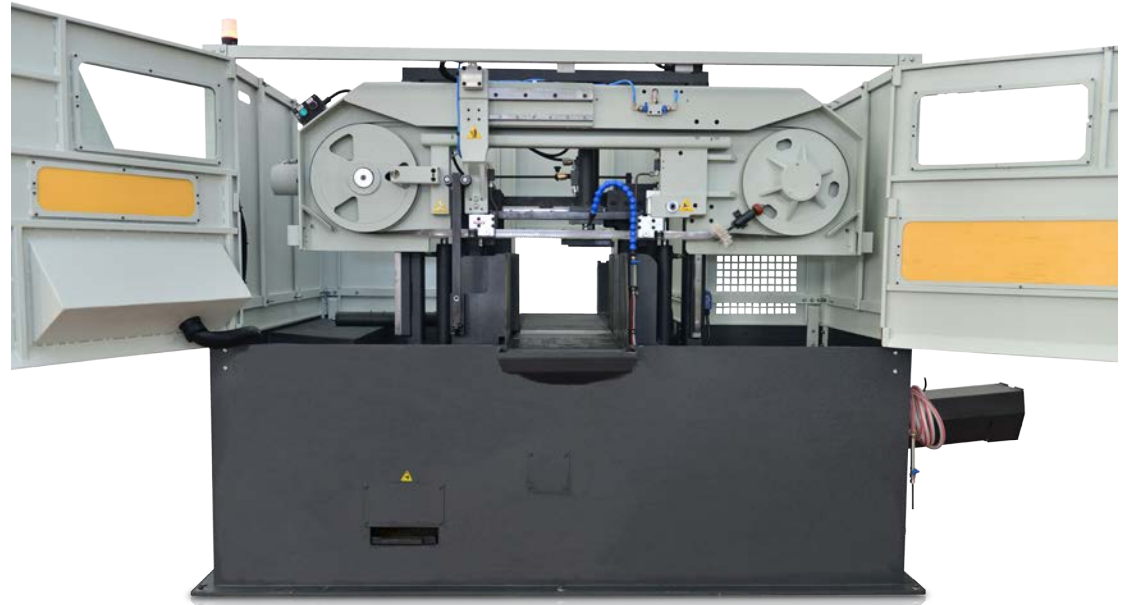

Hidrolik Üst Baskı



3 Metre Malzeme Sehpa



Mikrosprey Soğutucu



Paket Kesim Mengeneri



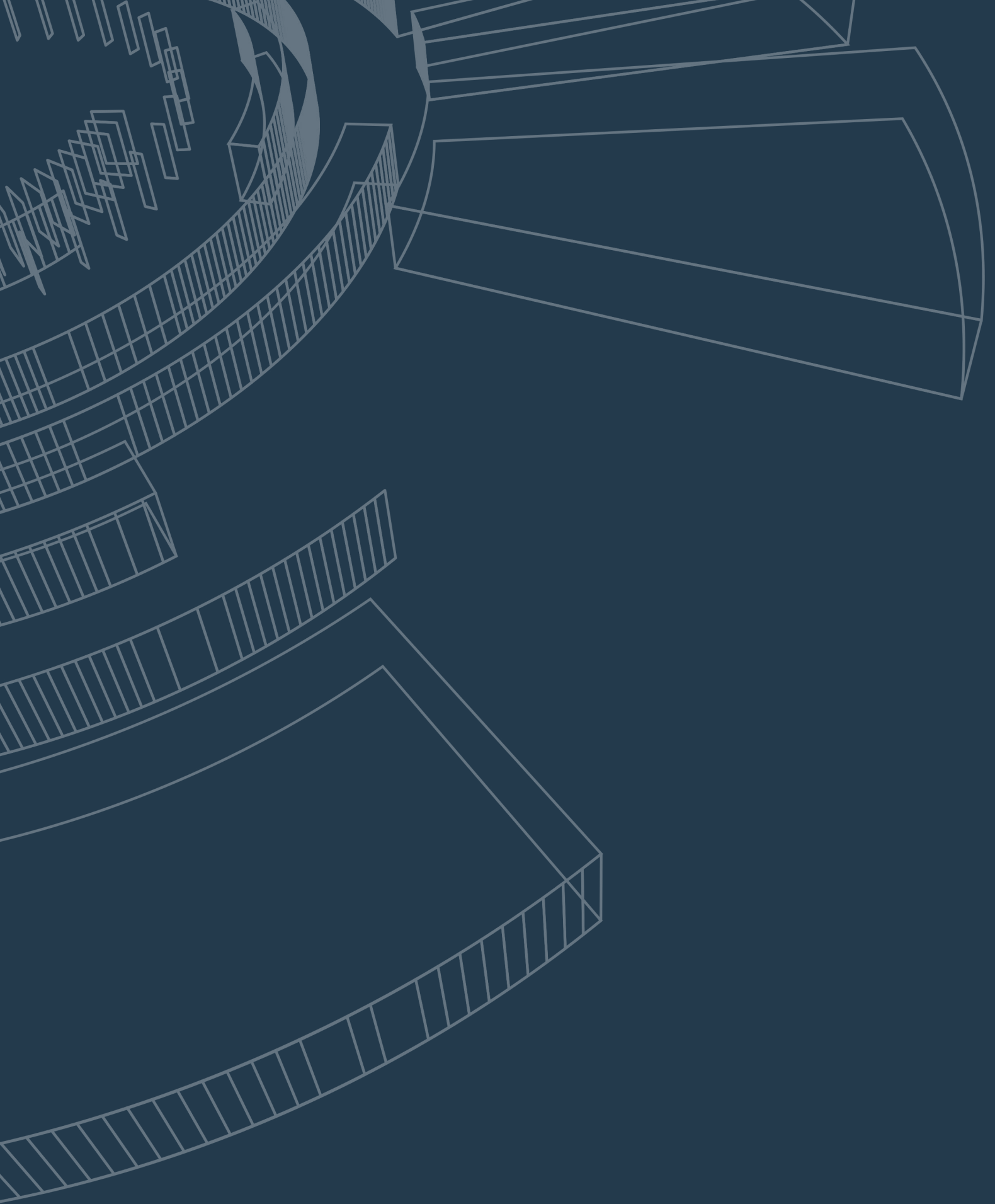

OTOMATİK SÜRÜCÜLÜ TEK TARAF AÇILI ŞERİT TESTERE MODELLERİ

BMSO 540 CGH/CGS NC - BMSO 440 CGH/CGS NC
BMSO 360 CGH/CGS NC - BMSO 325 CGH/CGS NC
BMSO 320 GHL NC/GSL NC - BMSO 320 GH NC/GS NC
BMSO 320 H NC/S NC - BMSO 320 LH NC/LS NC

500 mm Kurslu Hidrolik Sürücü (CGH)

700 mm Kurslu Servo Sürücü (CGS)

Tek Taraf Açılı Kesim

PLC Kontrol Paneli



Model	Sayfa
BMSO 540 CGH/CGS NC	26
BMSO 440 CGH/CGS NC	28
BMSO 360 CGH/CGS NC	29
BMSO 325 CGH/CGS NC	29
BMSO 320 GHL NC/GSL NC	30
BMSO 320 GH NC/GS NC	31
BMSO 320 H NC/S NC	32
BMSO 320 LH NC/LS NC	33

BMSO 540 CGH/CGS NC

CGH Tam Otomatik Hidrolik Sürüclü Açılı Şerit Testere Makinası

CGS Tam Otomatik Servo Sürüclü Açılı Şerit Testere Makinası

Standartlar

PLC Kontrol Paneli
Lineer Kızak
Hidromekanik Şerit Germe
Kesim Genişlik Ayar Kolu
Planet Redüktör
Hız Kontrol cihazı
Hassas Basınç Ayarı
Hidrolik Açılı Sabitleme
Kapak Switch
Sap Boryağ Pompası

Talaş Fırçası
Optik Yükseklik Ayarı
3° Eğik Kafa
Hidrolik Mengene
Saplanma Sensörü

Opsiyonel

Paket Kesim Çenesi
Mikrosprey Soğutucu
3 mt Malzeme Sehpası
Talaş Konveyoru
Hidrolik Üst Baskı
Lazer İşaretleyici
Hidrolik Şerit Germe



Paket Kesim
Çeneleri



Mikrosprey Soğutucu



Teknik Özellikler

				
Kesme Kapasitesi	0°	540	670 x 540	540
	30°	540	670 x 540	540
	45°	510	450 x 540	450
	60°	270	250 x 540	250
Ana Motor	4 kW			
Hidrolik Motor	1,1 kW			
Soğutucu Motor	0,12 kW			
Kesme Hızları	20 - 100 m/min			
Sürücü Kurs Boyu	500 mm (CGH) - 700 mm (CGS)			
Şerit Testere Ölçüsü	6000 x 41 x 1,3 mm			
Malzeme Besleme Yüksekliği	810 mm			
Ebatlar	Uzunluk 3100 mm	Genişlik 2350 mm	Yükseklik 2150 mm	Ağırlık 3850 kg

** 45 dereceden büyük açılı kesimlerde hidrolik üst baskı işlevsizdir.*

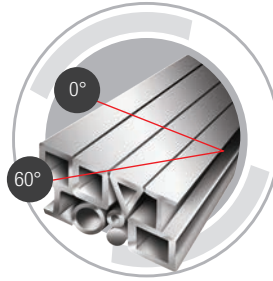

3 Mt Malzeme Sehpası

Talaş Konveyör

Hidrolik Üst Baskı

Lazer İşaretleyici

Hidrolik Şerit Germe

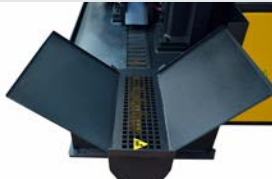

BMSO 440 CGH/CGS NC

BMSO 360 CGH/CGS NC

BMSO 325 CGH/CGS NC

CGH Tam Otomatik Hidrolik Sürüclü Açılı Şerit Testere Makinası
CGS Tam Otomatik Servo Sürüclü Açılı Şerit Testere Makinası

Standartlar

Şerit Testere Bıçağı 41
3° Eğik Kafa
Talaş Fırçası
PLC Kontrol Paneli
Kesim Genişlik Ayar Kolu
Optik Yükseklik Ayarı
Hassas Basınç Ayarı
Hidromekanik Şerit Germe
Hidrolik Açılı Sabitleme

Sap Boryağ Pompası
Planet Redüktör
Hidrolik Mengene
Lineer Kızak
Kapak Switch
Hız Kontrol cihazı
Şerit Sıkışmasında Koruma Switch

Opsiyonel

Hidrolik Şerit Germe
Paket Kesim Çeneleri
3 mt Malzeme Sehpa
Hidrolik Üst Baskı
Mikrosprey Soğutucu
Talaş Konveyoru
Lazer İşaretleyici

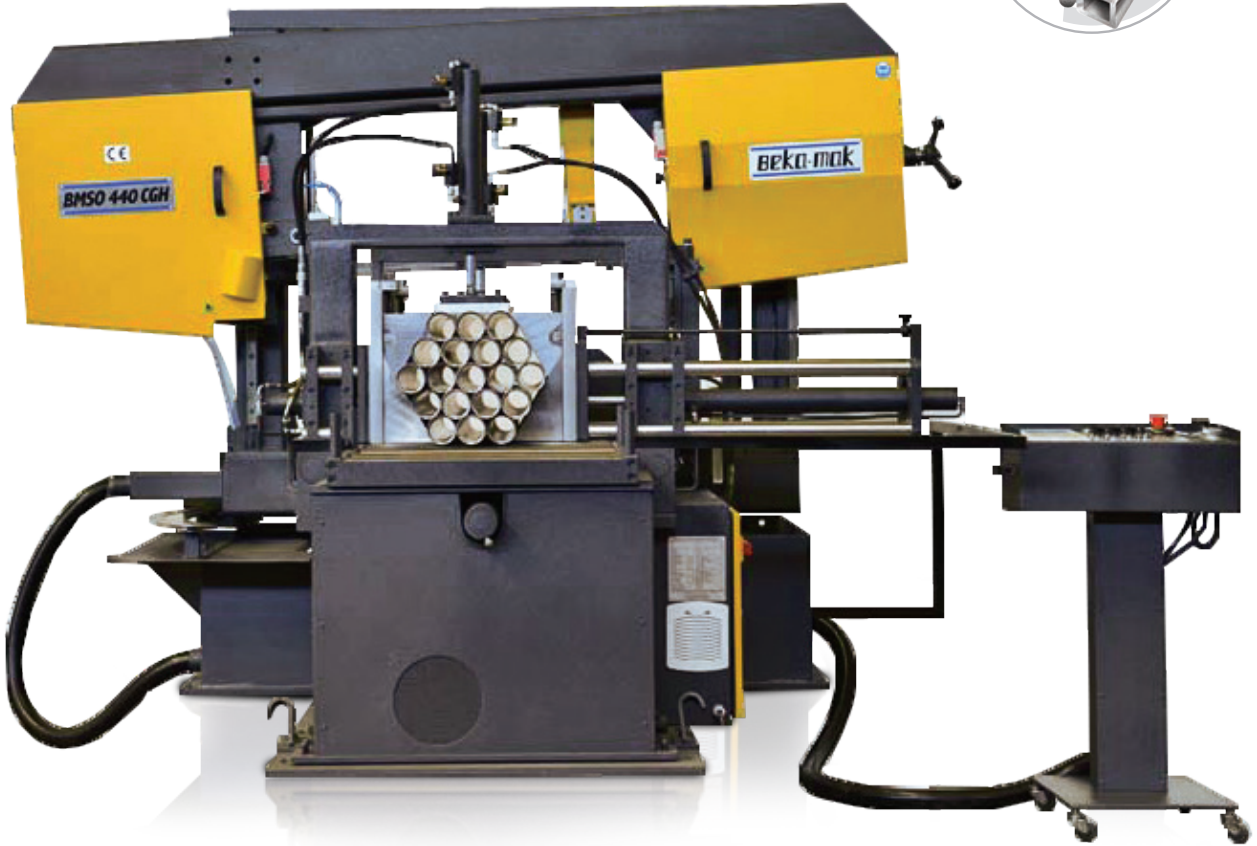
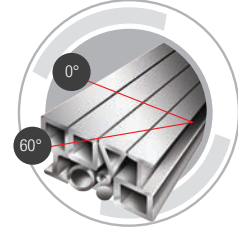

Paket Kesim
Çeneleri



Mikrosprey
Soğutucu



3 Mt Malzeme
Sehpa



Talaş Konveyoru

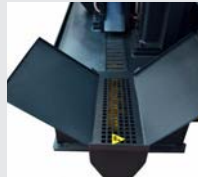

Hidrolik Üst Baskı















Lazer İşaretleyici



Hidrolik Şerit Germe



Teknik Özellikler

	BMSO 440 CGH/CGS NC				BMSO 360 CGH/CGS NC				BMSO 325 CGH/CGS NC			
												
Kesme Kapasitesi	0°	450	610 x 425	425	0°	360	610 x 360	360	0°	325	400 x 315	315
	30°	450	560 x 425	425	30°	360	590 x 360	360	30°	325	380 x 315	315
	45°	430	430 x 425	425	45°	360	450 x 360	360	45°	300	300 x 315	300
	60°	320	260 x 425	290	60°	325	280 x 360	290	60°	200	200 x 315	200
Ana Motor	4 kW				3 kW				2,2 kW			
Hidrolik Motor	2,2 kW				1,5 kW				1,5 kW			
Soğutucu Pump	0,12 kW				0,12 kW				0,12 kW			
Kesme Hızları	20 - 100 m/min				20 - 100 m/min				20 - 100 m/min			
Şerit Testere Ölçüsü	5400 x 41 x 1,3 mm				5200 x 34 x 1,1 mm				4380 x 34 x 1,1mm			
Malzeme Besleme Yüksekliği	735 mm				735 mm				655 mm			
Ebatlar	Uzunluk 2850 mm	Yükseklik 1950 mm			Uzunluk 2850 mm	Yükseklik 1820 mm			Uzunluk 2130 mm	Yükseklik 1650mm		
	Genişlik 2100 mm	Ağırlık 2480 kg			Genişlik 2100 mm	Ağırlık 2400 kg			Genişlik 2150 mm	Ağırlık 1860 kg		

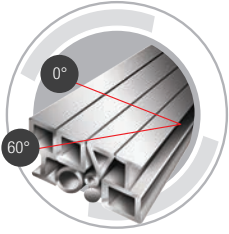

BMSO 320 GLH NC/GLS NC

BMSO 320 GH NC/GS NC

GLH Tam Otomatik Hidrolik Sürüclü Açılı Şerit Testere Makinası

GLS Tam Otomatik Servo Sürüclü Açılı Şerit Testere Makinası

Standartlar

Hız Kontrol Cihazı
Talaş Fırçası
Kapak Swich
Açılır Arka Mengene
Hareketli Mengene
PLC Kontrol Paneli

Yükseklik Ayar Swich
Hidromekanik Şerit Germe
SAP Boryağ Pompası
Hidrolik Mengene
Açı Ayarlama Göstergesi

Opsiyonel

Hassas Basınç
Paket Kesim Çenesi
Mikrosprey Soğutucu
Hidrolik Şerit Germe
3 Mt Malzeme Sehpa
Hidrolik Üst Baskı

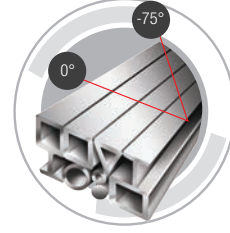

Teknik Özellikler

BMSO 320 GLH NC/GSL NC

BMSO 320 GH NC/GS NC

Kesme Kapasitesi	0°	320	610 x 320	320	0°	320	350 x 320	320
	-30°	260	280 x 200	225	-30°	160	150 x 150	150
	-45°	320	355 x 320	320	-45°	260	250 x 180	180
	-60°	320	510 x 320	320	-60°	300	300 x 200	250
	-75°	320	580 x 320	320	-75°	320	350 x 200	300
Ana Motor	2,2 kW				2,2 kW			
Hidrolik Motor	1,1 kW				1,1 kW			
Soğutucu Motor	0,12 kW				0,12 kW			
Kesme Hızları	20 - 100 m/min				20 - 100 m/min			
Şerit Testere Ölçüsü	4160 x 34 x 1,1 mm				3660 x 27 x 0,9 mm			
Malzeme Besleme Yüksekliği	740 mm				740 mm			
Ebatlar	Uzunluk 2370 mm Genişlik 2400 mm		Yükseklik 1500 mm Ağırlık 2060 kg		Uzunluk 2100 mm Genişlik 2200 mm		Yükseklik 1500 mm Ağırlık 1660 kg	

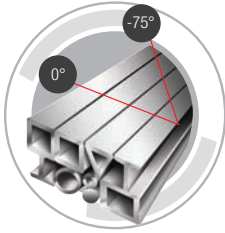

Hassas Basınç



Mikrosprey Soğutucu



Talaş Konveyörü

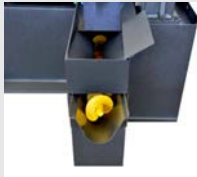

Hidrolik Şerit Germe



3 Metre Malzeme
Sehpası



Paket Kesim Çenesi



Hidrolik Üst Baskı



BMSO 320 H NC/S NC

BMSO 320 LH NC/LS NC

H Tam Otomatik Hidrolik Sürüclü Şerit Testere Makinası
S Tam Otomatik Servo Sürüclü Şerit Testere Makinası

Standartlar

Hız Kontrol Cihazı
Talaş Fırçası
Kapak Swich
Açılır Arka Mengene
Hareketli Mengene
PLC Kontrol Paneli
Yükseklik Ayar Swich
Hidromekanik Şerit Germe
SAP Boryağ Pompası
Hidrolik Mengene

Opsiyonel

Hassas Basınç
Paket Kesim Çenesi
Mikrosprey Soğutucu
Hidrolik Şerit Germe
3 Mt Malzeme Sehpa
Hidrolik Üst Baskı

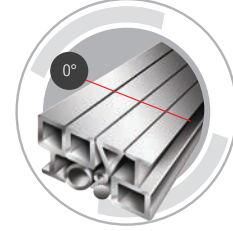

Mikrosprey Soğutucu

Hidrolik Şerit Germe

Hassas Basınç

Chip Conveyor

3 Mt Malzeme Sehpa

Hidrolik Üst Baskı







Paket Kesim Çeneleri



Teknik Özellikler

BMSO 320 H NC/S NC

BMSO 320 LH NC/LS NC

									
Kesme Kapasitesi	0°	320	350 x 320	320	0°	320	610 x 320	320	
Ana Motor	2,2 kW				2,2 kW				
Hidrolik Motor	1,5 kW				1,5 kW				
Soğutucu Motor	0,12 kW				0,12 kW				
Kesme Hızları	20 - 100 m/min				20 - 100 m/min				
Şerit Testere Ölçüsü	3660 x 27 x 0,9 mm				4160 x 34 x 1,1 mm				
Malzeme Besleme Yüksekliği	700 mm				700 mm				
Ebatlar	Uzunluk 2000 mm		Yükseklik 1250 mm		Uzunluk 2100 mm		Yükseklik 1250 mm		
	Genişlik 1850 mm		Ağırlık 1340 kg		Genişlik 1850 mm		Ağırlık 1585 kg		

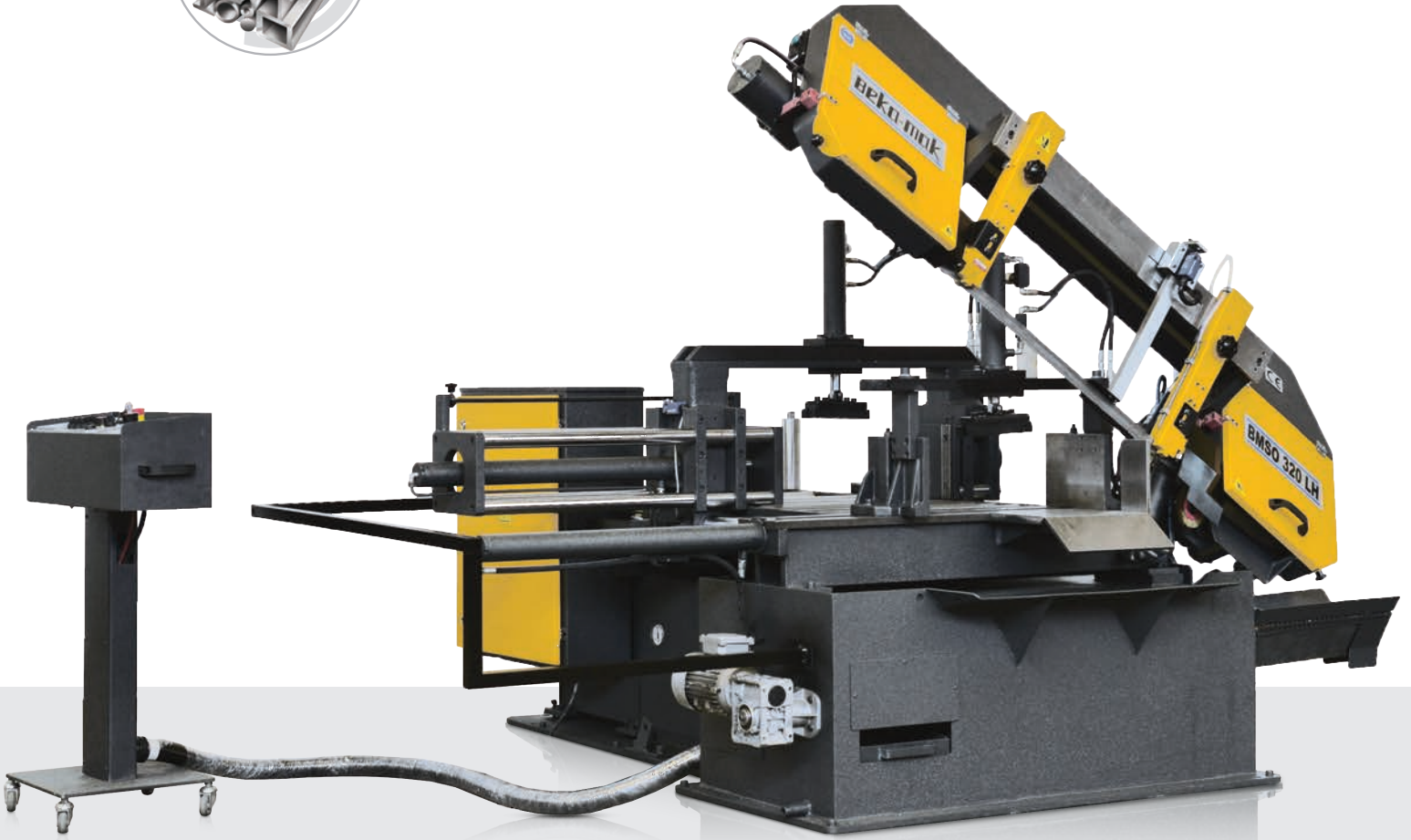
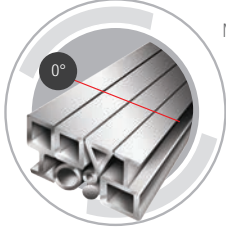

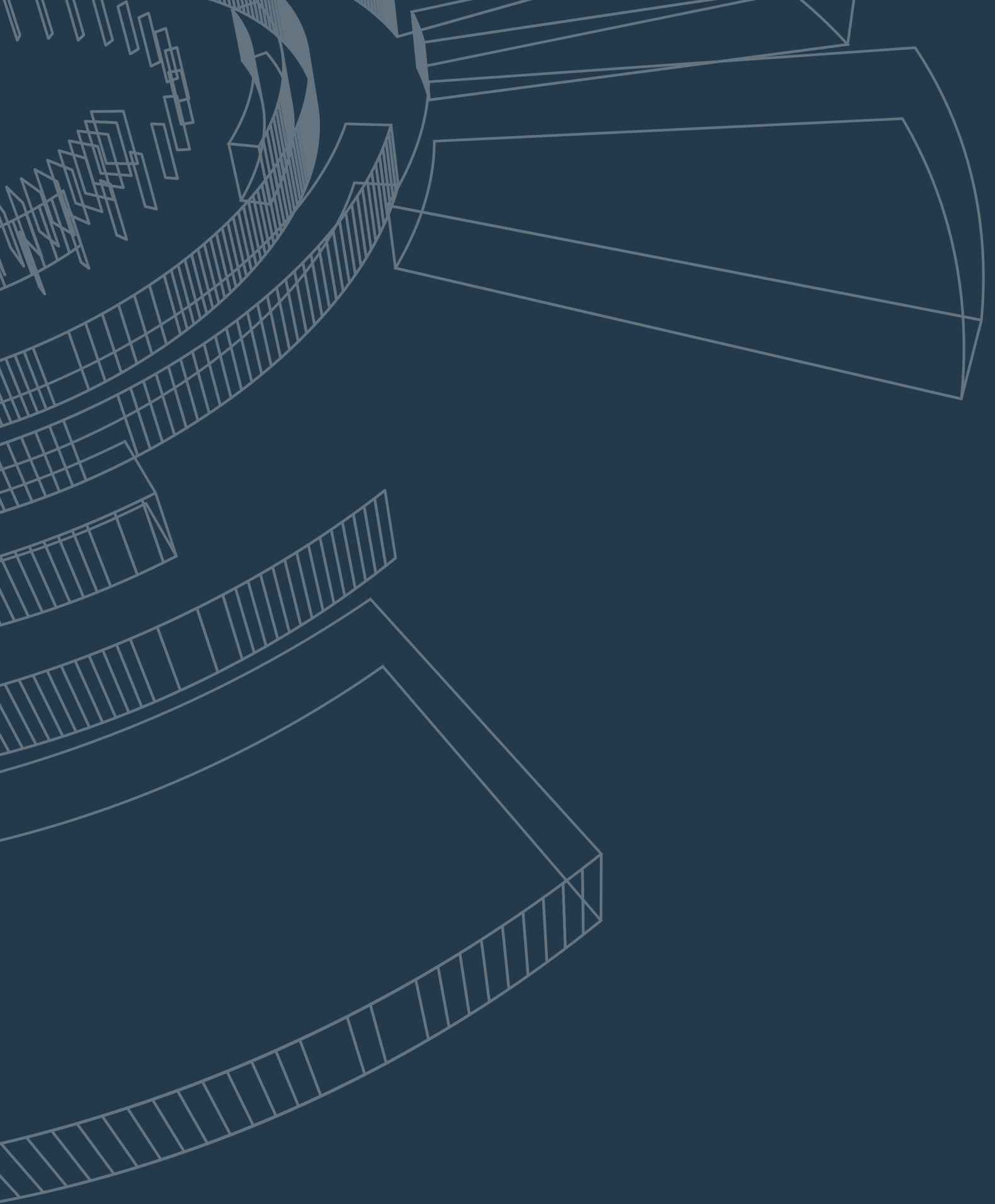

ÇİFT TARAFA AÇILI SÜTUNLU YARI OTOMATİK ŞERİT TESTERE MAKİNA MODELLERİ

**BMSY 650 DG NC - BMSY 750 DG NC - BMSY 560 DG
BMSY 560 DG NC- BMSY 440 CDGH
BMSY 440 CDGH NC - BMSY 360 CDGH**

Yarı otomatik çift tarafa açılı şerit testere modellerimiz malzemelerin takla attırılmadan iki yönlü de açılı kesim yapılmasını sağlar. Standart modellerde kafa açığı manuel olarak dijital açı göstergesinden kontrol edilerek döndürülür. NC opsiyonlu makinelerimizde ise kafanın açığı PLC kontrol panelinden otomatik ayarlanarak zamandan tasarruf edilmesi sağlanır.



Model	Sayfa
BMSY 650 DG NC	36
BMSY 750 DG NC	37
BMSY 560 DG	38
BMSO 560 DG NC	38
BMSY 440 CDGH	39
BMSO 440 CDGH NC	39
BMSY 360 CDGH	40

BMSY 650 DG NC - BMSY 750 DG NC

Çift Taraf Açılı Sütunlu Yarı Otomatik Testere Makinası

Standartlar





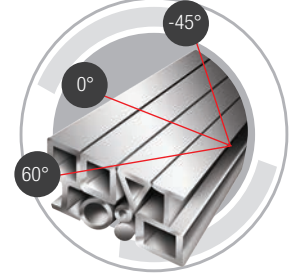

PLC Kontrol Paneli
Planet Redüktör
Şerit Testere 54
Döner Tabla
Güvenlik Sensörlü Halat
Hidrolik Mengene
Motorlu Talaş Fırçası
Kapak Swich
Kesim Genişlik Ayar Kolu
Hassas Basınç
Hidrolik Şerit Germe
Hız Kontrol Cihazı
Talaş Konveyör
Lineer Kızak
Yükseklik Ayar Sensörü
Şerit Sıkışmasında
Koruma Swich

Opsiyonel

Lazer İşaretleyici
3 Mt Malzeme Sehpa
3 mt Motorlu Sehpa
Mikrosprey Soğutucu
Hidrolik Üst Baskı



Teknik Özellikler

	BMSY 650 DG NC				BMSY 750 DG NC			
								
Kesme Kapasitesi	0°	650	1000 x 600	600	0°	800	1300 x 750	800
	30°	650	840 x 600	600	30°	800	1070 x 750	770
	45°	650	660 x 600	600	45°	800	850 x 750	770
	60°	440	440 x 600	440	60°	570	570 x 750	570
	-30°	650	840 x 600	600	-30°	800	1070 x 750	770
	-45°	650	660 x 600	600	-45°	800	570 x 750	770
Ana Motor	7,5 kW				7,5 kW			
Hidrolik Motor	4 kW				4 kW			
Soğutucu Motor	0,12 kW				0,12 kW			
Açı Motoru	0,37 kW				0,37 kW			
Talaş Konveyör Motoru	0,25 kW				0,25 kW			
Motorlu Talaş Fırçası	0,18 kW				0,18 kW			
Kesme Hızları	20 - 100 m/min				20 - 100 m/min			
Şerit Testere Ölçüsü	8400 x 54 x 1,6 mm				9600 x 54 x 1,6 mm			
Malzeme Besleme Yüksekliği	880 mm				880 mm			
Ebatlar	Uzunluk 4750 mm		Yükseklik 2630 mm		Uzunluk 5050 mm		Yükseklik 2900 mm	
	Genişlik 1970 mm		Ağırlık 6520 kg		Genişlik 2200 mm		Ağırlık 6700 kg	



Lazer İşaretleyici



3 Mt Malzeme Sehpaı



3 Mt Motorlu Sehpa



Mikrosprey Soğutucu



Hidrolik Üst Baskı



BMSY 560 DG / BMSY 560 DG NC BMSY 440 CDGH / BMSY 440 CDGH NC

Çift Taraf Açılı Sütunlu Yarı Otomatik Testere Makinası

Standartlar

PLC Kontrol Paneli (NC Model)	3° Eğik Kafa
Planet Redüktör	Döner Tabla
Hidromekanik Şerit Germe	Lineer Kızak
Optik Yükseklik Ayarı	Kapak Swich
Talaş Fırçası	Şerit Sıkışmasında Koruma Swich
Hassas Basınç Ayarı	Hassas Kesim Ayarı
Kesim Genişlik Ayar Kolu	Sap Boryağ Pompası
Hız Kontrol Cihazı	Hidrolik Mengene
Kumando Panosu	Hidrolik Açılı Sabitleme
Şerit Testere 41	

Opsiyonel

Hidrolik Şerit Germe
3 mt Malzeme Sehpa
3 mt Motorlu sehpa
Hidrolik Üst Baskı
Mikrosprey Soğutucu
Lazer İşaretleyici
Talaş Konveyör

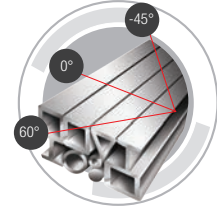

Hidrolik Şerit Germe



3 mt Malzeme Sehpa



3 Mt Motorlu Sehpa



Hidrolik Üst Baskı



Mikrosprey Soğutucu



Lazer İşaretleyici









Talaş Konveyör



Teknik Özellikler

BMSY 560 DG / DG NC

BMSY 440 CDGH / CDGH NC

									
Kesme Kapasitesi	0°	560	820 x 540	540	0°	440	640 x 440	440	440
	30°	560	705 x 540	540	30°	440	510 x 440	440	440
	45°	550	550 x 540	540	45°	440	400 x 440	400	400
	60°	360	360 x 540	360	60°	250	250 x 440	250	250
	-30°	500	705 x 540	540	-30°	440	510 x 440	440	440
	-45°	550	550 x 540	540	-45°	390	390 x 440	390	390
Ana Motor	4 kW				4 kW				
Hidrolik Motor	1,5 kW				1,1 kW				
Soğutucu Motor	0,12 kW				0,12 kW				
Açı Motoru	0,37 kW (NC Model)				-				
Kesme Hızları	20 - 100 m/min				20 - 100 m/min				
Şerit Testere Ölçüsü	6800 x 41 x 1,3 mm				5200 x 41 x 1,3 mm				
Malzeme Besleme Yüksekliği	880 mm				800 mm				
Ebatlar	Uzunluk 3800 mm		Yükseklik 2350 mm		Uzunluk 3100 mm		Yükseklik 1910 mm		
	Genişlik 1750 mm		Ağırlık 3200 kg		Genişlik 1200 mm		Ağırlık 1780 kg		

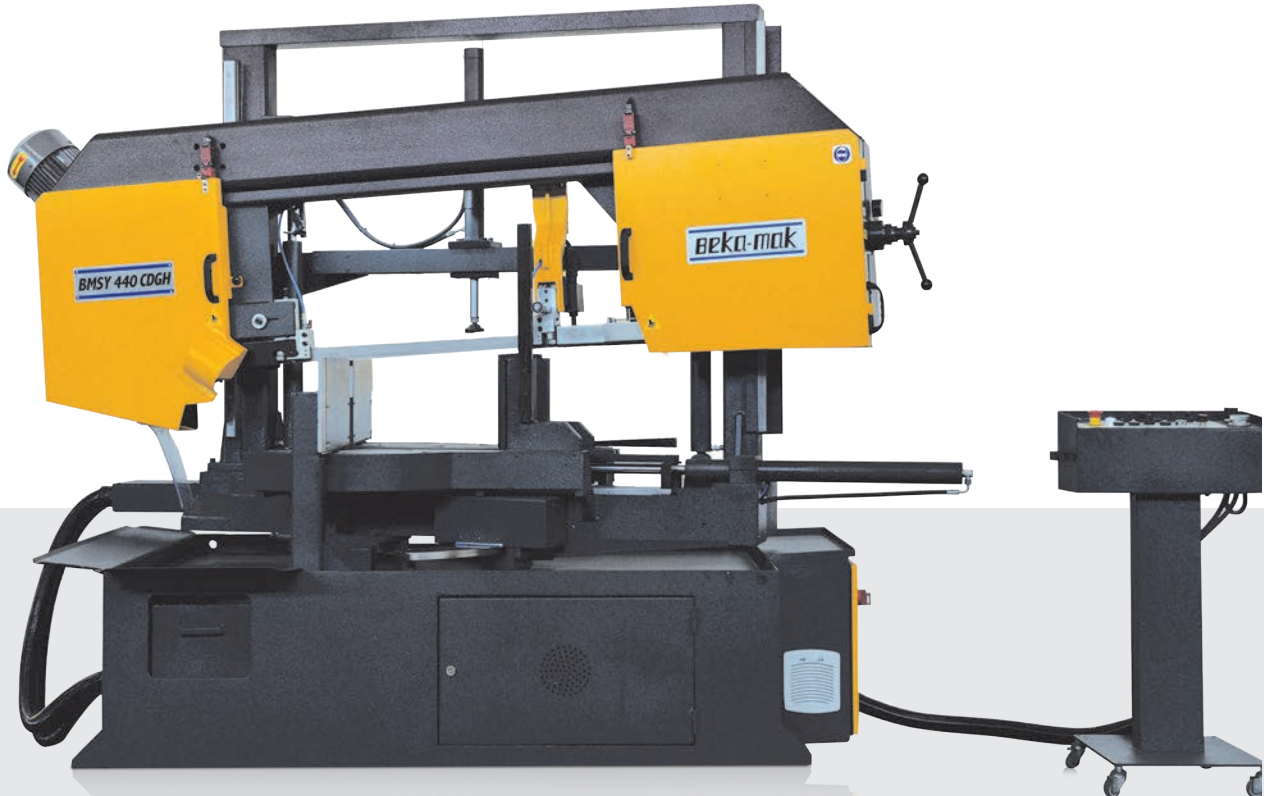
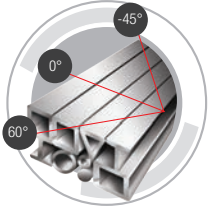

BMSY 360 CDGH

Çift Taraf Açılı Sütunlu Yarı Otomatik Testere Makinası

Standartlar

Hız Kontrol Cihazı
Kumando Panosu
Hassas Kesim Ayarı
Şerit Testere 34
SAP Boryağ Pompası
Kapak Swich
Optik Yükseklik Ayarı
Kesim Genişlik Ayar Kolu

Hidromekanik Şerit Germe
Lineer Kızak
Planet Redüktör
3° Eğik Kafa
Talaş Fırçası
Hidrolik Açılı Sabitleme
Hidrolik Mengene

Opsiyonel

Hidrolik Şerit Germe
3 Mt Motorlu Sehpa
3 mt Malzeme Sehpası
Hidrolik Üst Baskı
Lazer İşaretleyici
Mikrosprey Soğutucu



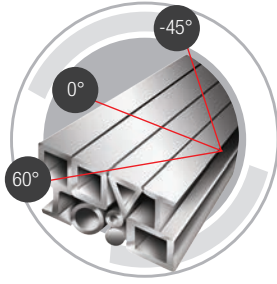

Teknik Özellikler

	△	○	□	□
Kesme Kapasitesi	0°	360	640 x 360	360
	30°	360	510 x 360	360
	45°	360	390 x 360	360
	60°	310	250 x 360	270
	-30°	360	510 x 360	360
	-45°	360	390 x 360	360
	Ana Motor	3 kW		
Hidrolik Motor	1,1 kW			
Soğutucu Motor	0,12 kW			
Kesme Hızları	20 - 100 m/min			
Şerit Testere Ölçüsü	5000 x 34 x 1,1 mm			
Malzeme Besleme Yüksekliği	800 mm			
Ebatlar	Uzunluk 3000 mm		Yükseklik 1910 mm	
	Genişlik 1200 mm		Ağırlık 1635 kg	



Hidrolik Şerit Germe

3 Mt Motorlu Sehpa

3 Mt Malzeme Sehpa

Hidrolik Üst Baskı

Lazer İşaretleyici

Mikrosprey Soğutucu

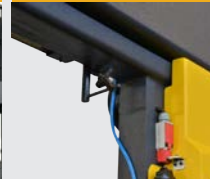

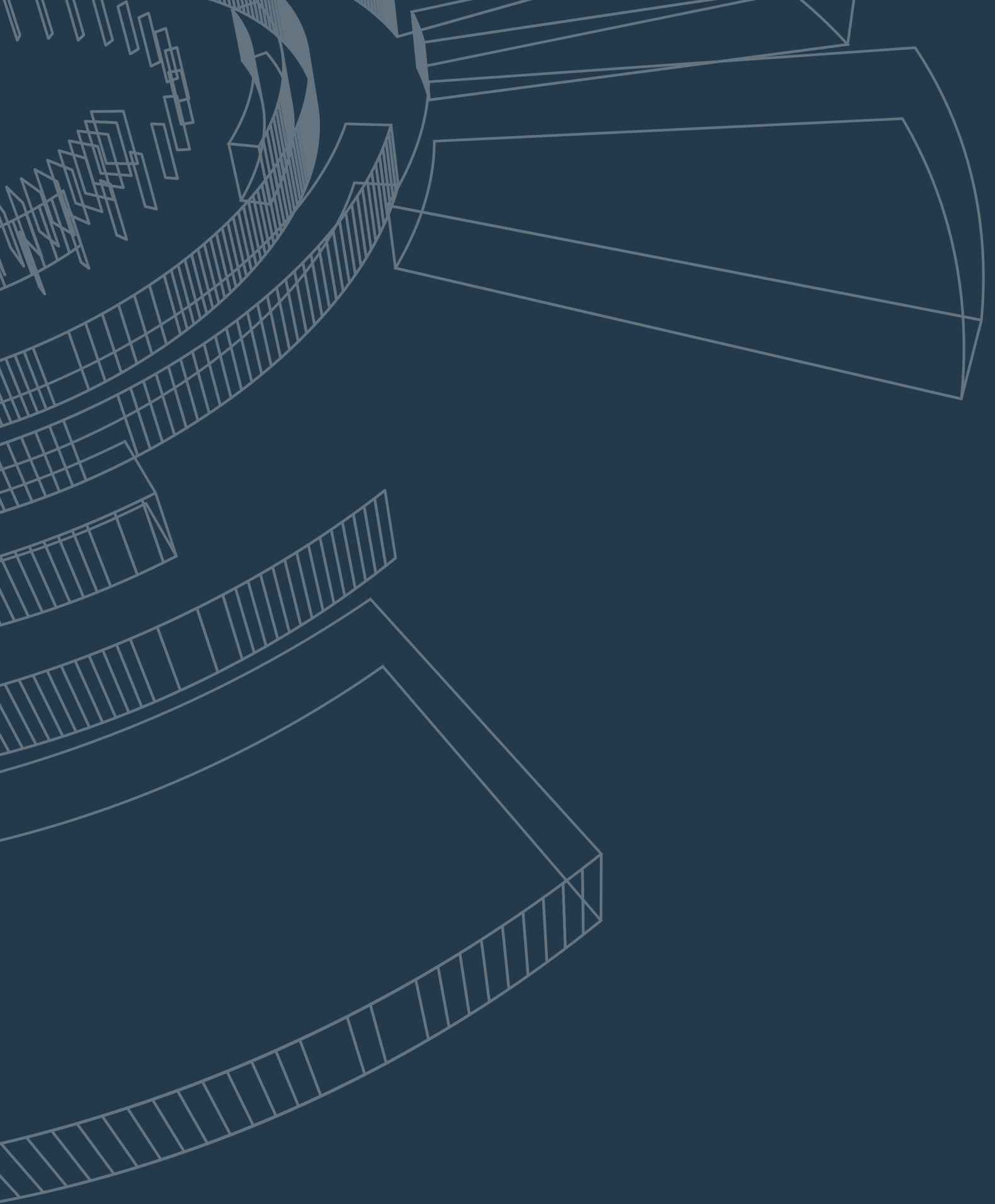

AĞIR TİP SÜTUNLU YARI OTOMATİK ŞERİT TESTERE MAKİNA MODELLERİ

BMSY 1515C - BMSY 1122C
BMSY 1313C - BMSY 1113C
BMSY 1110C

Güçlü gövde, platina kafa, yüksek verimli motor ve planet redüktörle kesilmesi zor malzemelerin kesimlerinde dünya standartlarında kesim sürelerini yakalayan bu modellerimiz, uzun ömürlü bıçak kullanımıyla da akıllı yatırım için oldukça elverişlidir.



Model	Sayfa
BMSY 1515C	44
BMSY 1122C	46
BMSY 1313C	48
BMSY 1113C	50
BMSY 1110C	51

BMSY 1515C

Ađır Tip Sütunlu Yarı Otomatik Şerit Testere Makinası

Standartlar

Hidrolik Çift Mengene
Planet Redüktör,
Piano Tip Kontrol Paneli
Hidrolik Gezer Kol
Saplanma Sensörü
Şerit Kopma Sensörü
Led Lamba
Motorlu Talaş Fırçası
Paletli Talaş Konveyör

Opsiyonel

3 mt Motorlu Sehpa
3 mt Malzeme Sehpa
Kesim Hızı Göstergesi
2° Eğik Kafa





Teknik Özellikler

				
Kesme Kapasitesi	0°	1500	1510x1500	1500
Ana Motor	15 kW			
Hidrolik Motor	7,5 kW			
Soğutucu Motor	2 x 0.20 kW			
Talaş Konveyör Motoru	0,25 kW			
Kesme Hızları	10 - 70 m/min			
Şerit Testere Ölçüsü	13350 x 80 x 1,6 mm			
Malzeme Besleme Yüksekliği	545 mm			
Ebatlar	Uzunluk 6400 mm Genişlik 2400 mm Yükseklik 3650 mm Ağırlık 25320 kg			

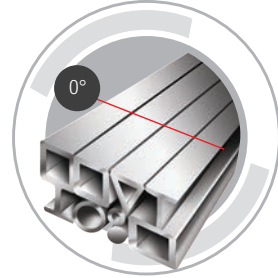

3 Mt Motorlu Sehpa



3 Mt Malzeme Sehpa



OPSİYONEL

BMSY 1122C

Ađır Tip Sütunlu Yarı Otomatik Şerit Testere Makinası

Standartlar

Hidrolik Çift Mengene
Planet Redüktör,
Piano Tip Kontrol Paneli
Hidrolik Gezer Kol
Saplanma Sensörü
Şerit Kopma Sensörü
Led Lamba
Motorlu Talaş Fırçası
Paletli Talaş Konveyör

Opsiyonel

4 Mt Besleme Sehpaı
2 Mt Çıkıř Sehpaı
Sapma Sensörü
Kesim Hızı Göstergesi
2° Açılı Kafa

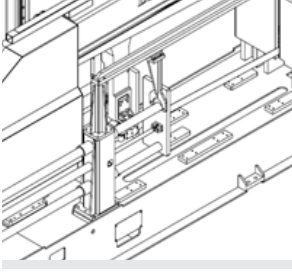
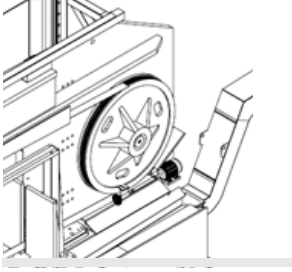

Teknik Özellikler

				
Kesme Kapasitesi	0°	1100	1100 x 2300	1100
Ana Motor	15 kW			
Hidrolik Motor	7,5 kW			
Soğutucu Motor	0,2 kW			
Talaş Konveyör Motoru	0,25 kW (Ops. 0,55 kW)			
Kesme Hızları	20 - 100 m/min			
Çalışma Yüksekliği	790			
Şerit Testere Ölçüsü	13100 x 80 x 1,6 mm			
Ebatlar	Uzunluk 7700 mm Genişlik 1250 mm Yükseklik 3400 mm Ağırlık 15700 kg			

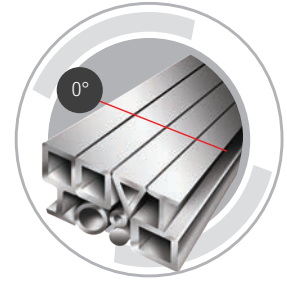

3 Mt Motorlu Sehpa



3 Mt Malzeme Sehpa



OPSİYONEL

BMSY 1313C

Ađır Tip Sütunlu Yarı Otomatik Şerit Testere Makinası

Standartlar

Planet Redüktör
Hidrolik Mengene
Kapak Swich
Hız Kontrol Cihazı
Hidrolik Şerit Germe
Kesim Genişlik Ayar Kolu
Kumando Panosu
Talaş Konveyörü
Lineer Kızak
Yükseklik Ayar Sensörü
Talaş Fırçası
Hassas Basınc Ayarı
Şerit Testere Bıçağı 67

Opsiyonel

Hidrolik Çift Mengene
3 mt Malzeme Sehpa
3 mt Motorlu Sehpa
Lazer İşaretleyici
Hidrolik Ust Baskı
Mikrosprey Soğutucu





Teknik Özellikler

				
Kesme Kapasitesi	0°	1300	1300x1300	1300
Ana Motor	11 kW			
Hidrolik Motor	7,5 kW			
Soğutucu Motor	0,2 kW			
Talaş Konveyör Motoru	0,25 kW			
Kesme Hızları	20 - 100 m/min			
Şerit Testere Ölçüsü	12100 x 67 x 1,6 mm			
Malzeme Besleme Yüksekliği	545 mm			
Ebatlar	Uzunluk 5300 mm Genişlik 1500 mm		Yükseklik 3175 mm Ağırlık 11500 kg	

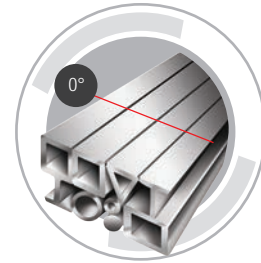

Hidrolik Çift Mengene



3 mt Malzeme
Sehpa



3 mt Motorlu Sehpa



Lazer İşaretleyici



Hidrolik Üst Baskı



Mikrosprey Soğutucu

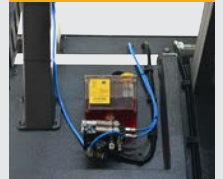

BMSY 1113C - BMSY 1110C

Ađır Tip Sütunlu Yarı Otomatik Şerit Testere Makinası

Standartlar

Şerit Testere Bıçađı 67
Hassas Basınc Ayarı
Talaş Fırçası
Yükseklik Ayar Sensörü
Şerit Sıkışmasında Koruma Swich
Planet Redüktör
Lineer Kızak
Talaş Konveyörü
Kumando Panosu
Kesim Genişlik Ayar Kolu
Hidrolik Şerit Germe
Hız Kontrol Cihazı
Kapak Swich

Opsiyonel

Hidrolik Çift Mengene
3 mt Motorlu Sehpa
3 mt Malzeme Sehpa
Mikrosprey Soğutucu
Lazer İşaretleyici

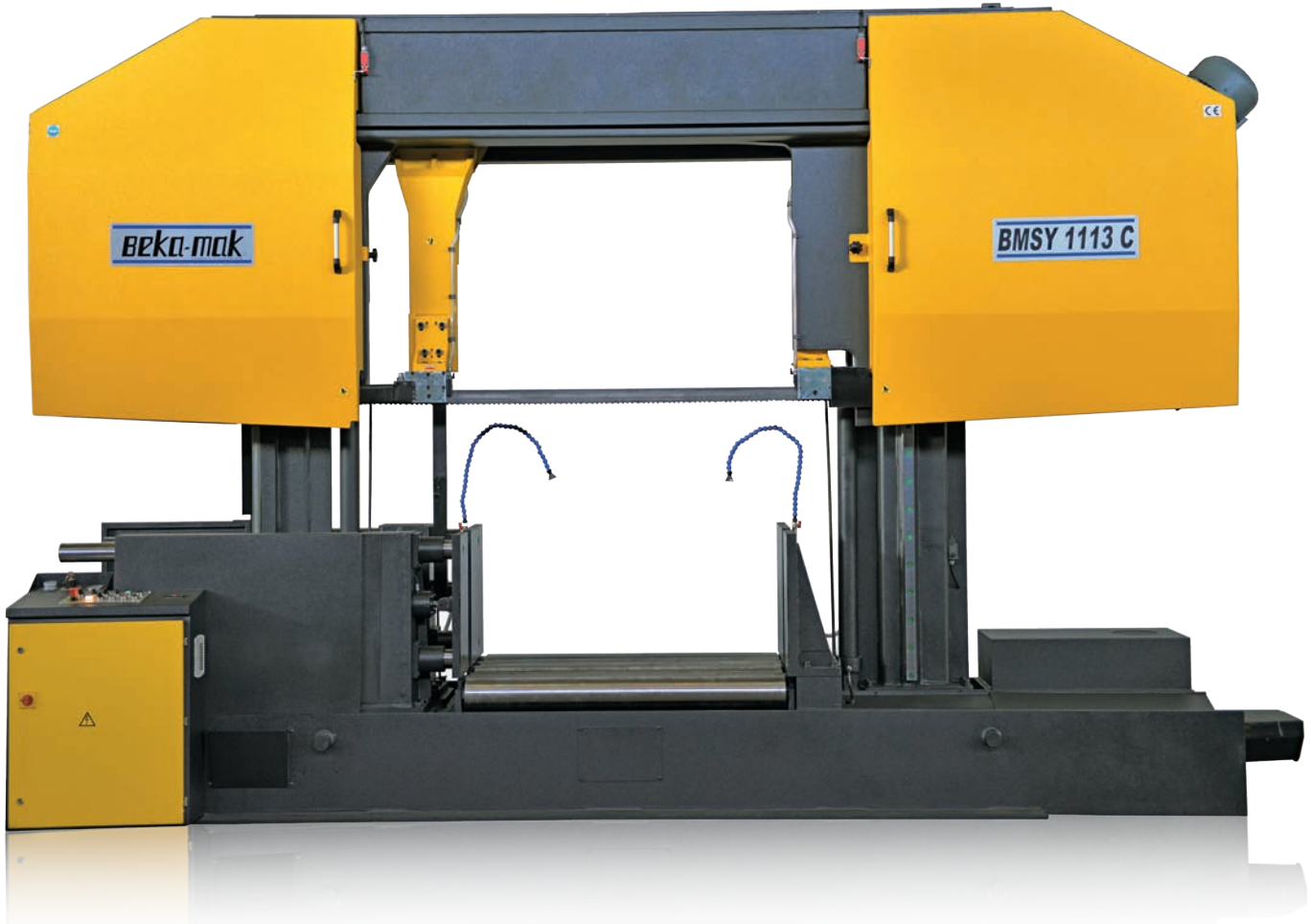
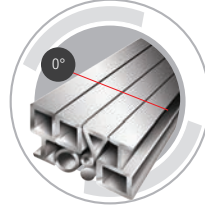

OPSIYONEL

Hidrolik Çift Mengene



3 mt Motorlu Sehpa



3 mt Malzeme Sehpa



Mikrosprey Soğutucu







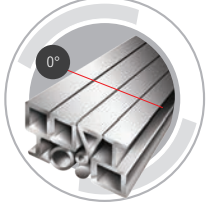



Lazer İşaretleyici





Teknik Özellikler

	BMSY 1113C				BMSY 1110C			
								
Kesme Kapasitesi	0°	1110	1110 x 1300	1110	0°	1110	1110 x 1110	1110
Ana Motor	11 kW				11 kW			
Hidrolik Motor	7,5 kW				4 kW			
Soğutucu Motor	0,20 kW				0,20 kW			
Talaş Konveyör Motoru	0,25 kW				0,25 kW			
Kesme Hızları	20 - 100 m/min				20 - 100 m/min			
Şerit Testere Ölçüsü	10900 x 67 x 1,6 mm				10500 x 67 x 1,6 mm			
Malzeme Besleme Yüksekliği	545 mm				545 mm			
Ebatlar	Uzunluk 5300 mm Genişlik 1500 mm		Yükseklik 2975 mm Ağırlık 11390 kg		Uzunluk 4800 mm Genişlik 1500 mm		Yükseklik 2975 mm Ağırlık 10440 kg	



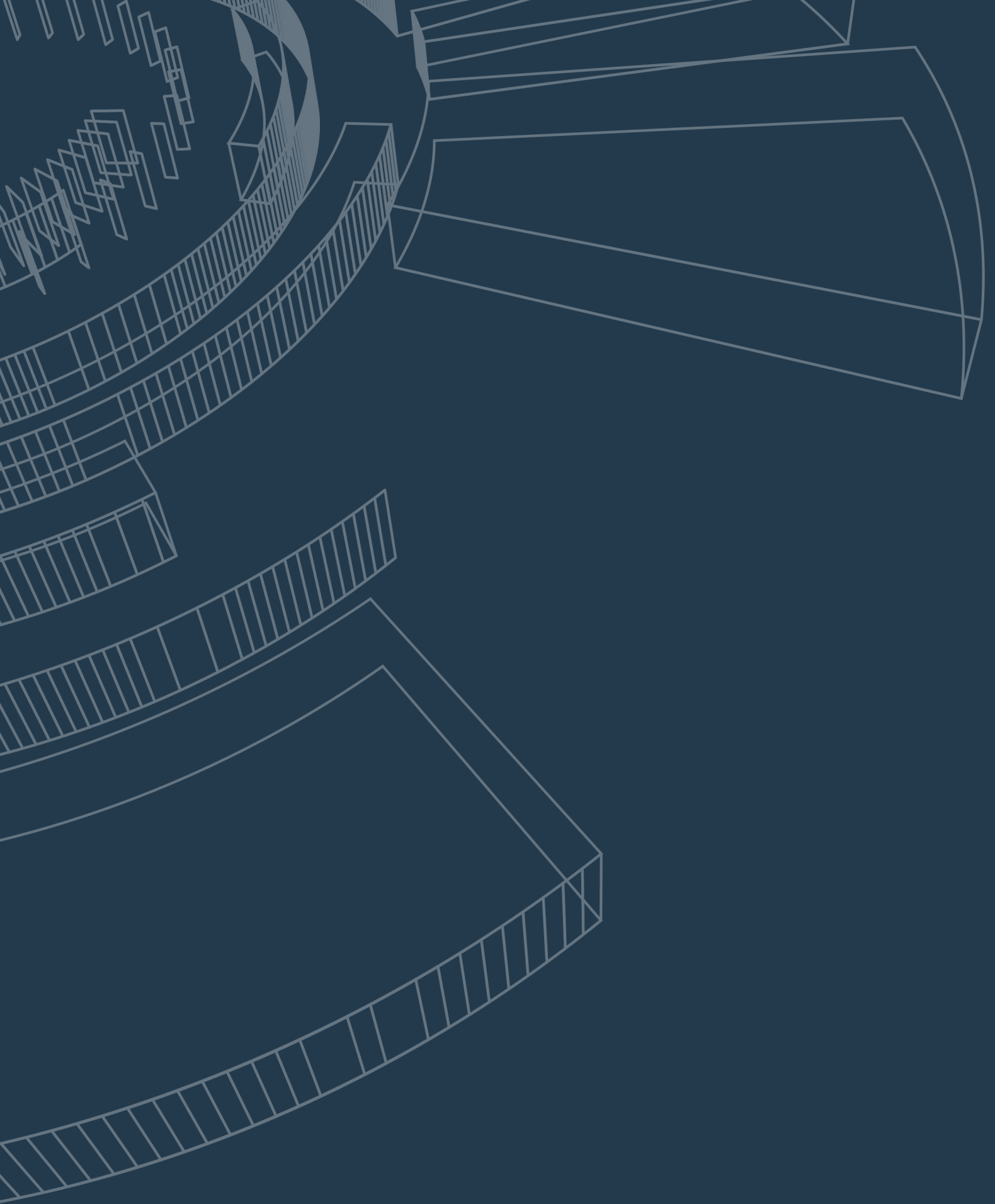

SÜTUNLU YARI OTOMATİK ŞERİT TESTERE MAKİNA MODELLERİ

BMSY 1020C - BMSY 820C - BMSY 810C
BMSY 650C - BMSY 570C - BMSY 560C
BMSY 460C - BMSY 360C - BMSY 325C

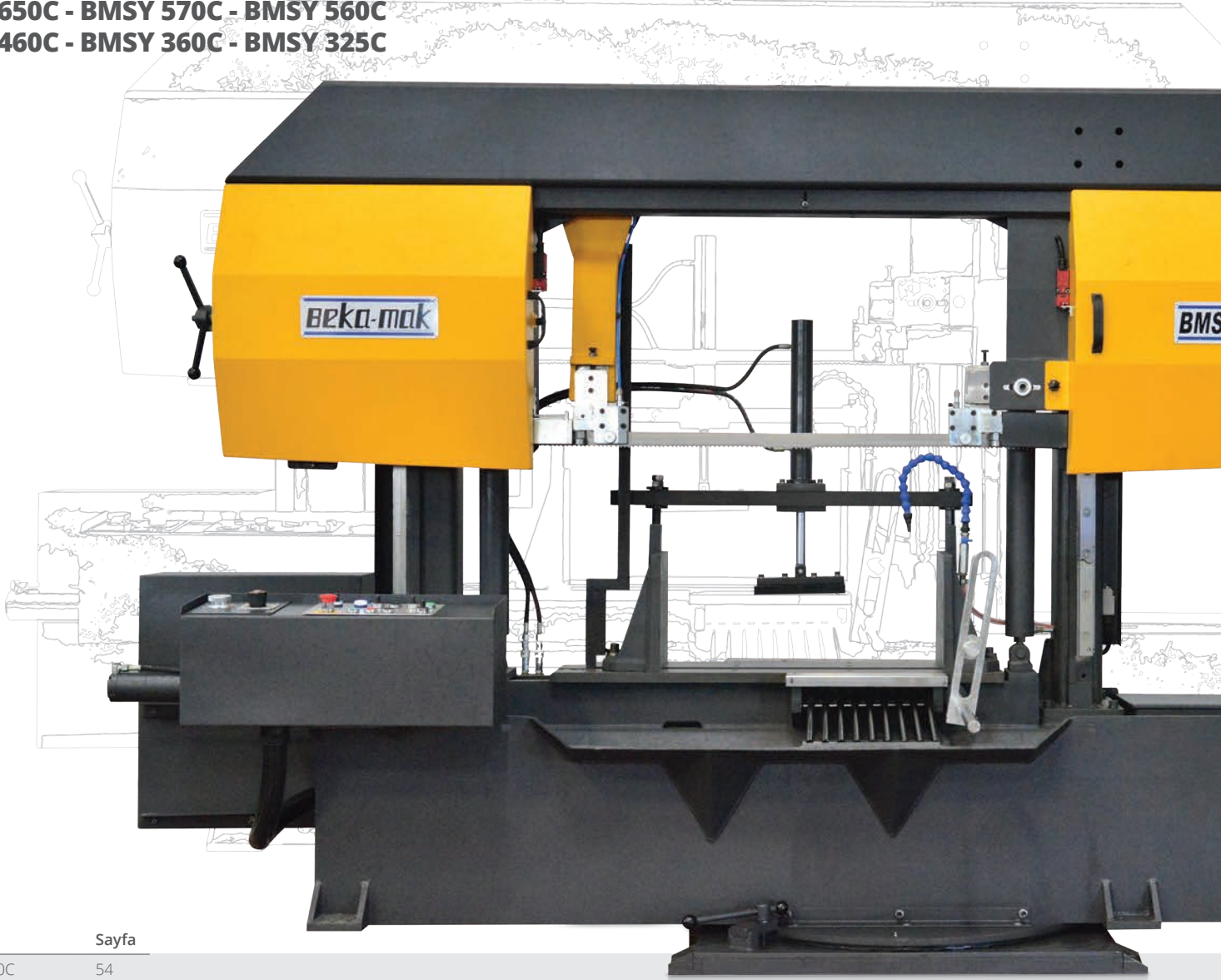

Model	Sayfa
BMSY 1020C	54
BMSY 820C	56
BMSY 810C	58
BMSY 650C	60
BMSY 570C	61
BMSY 560C	61
BMSY 460C	62
BMSY 360C	64
BMSY 325C	65

BMSY 1020C

Sütunlu Yarı Otomatik Şerit Testere Makinası

Standartlar

Planet Redüktör
Kontrol Paneli
Talaş Fırçası
Lineer Kızak
Hassas Basınç
Hidrolik Şerit Germe
Hidrolik Mengene
Optik Yükseklik Ayarı
Hız Kontrol Cihazı
Sap Boryağ Pompası
Besleme Sehpa
Kapak Swich
Şerit Testere Bıçağı 54

Opsiyonel

Talaş Konveyör
Lazer İşaretleyici
2° Eğik Kafa
Mikrosprey Soğutucu
3 Mt Motorlu Sehpa
3 mt Malzeme Sehpa
Hidrolik Üst Baskı



Teknik Özellikler

				
Kesme Kapasitesi	0°	1020	1020 x 1020	1020
Ana Motor	7,5 kW			
Hidrolik Motor	2,2 kW			
Soğutucu Motor	0,12 kW			
Talaş Konveyör Motoru	0,25 kW			
Kesme Hızları	20 - 100 m/min			
Şerit Testere Ölçüsü	9500 x 54 x 1,6 mm			
Malzeme Besleme Yüksekliği	535 mm			
Ebatlar	Uzunluk 4500 mm Genişlik 1700 mm Yükseklik 2750 mm Ağırlık 5860 kg			

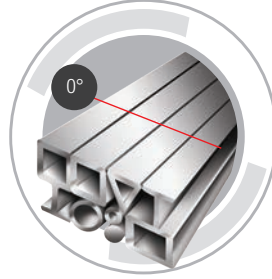

Talaş Konveyör



Lazer İşaretleyici



2° Eğik Kafa



Mikrosprey Soğutucu



3 Mt Motorlu Sehpa



3 mt Malzeme Sehpa



Hidrolik Üst Baskı



BMSY 820C

Sütunlu Yarı Otomatik Şerit Testere Makinası

Standards

Planet Redüktör
Hidrolik Mengene
Kesim Genişlik Ayar Kolu
Kapak Swich
Hassas Kesim Ayarı
Kontrol Paneli
Optik Yükseklik Ayarı
Hız kontrol cihazı
Talaş Fırçası
Lineer Kızak
Dayama
Sap Boryağ Pompası
1,2 mt Malzeme Sehpa
Yükseklik Ayar Sensörü
Hidromekanik Şerit Germe
Hassas Basınç Ayarı
Hidrolik Şerit Germe (BMSY 820 C)

Optionals

Yüksek Mengene Çeneleri
Çift Mengene
Demet Kesim Çeneleri
Lazer İşaretleyici
Talaş Konveyör
Hidrolik Üst Baskı
3 mt Motorlu Sehpa
3 mt Malzeme Sehpa
Mikrosprey Soğutucu
2° Eğik Kafa
Döner Tabla
Hidrolik Şerit Germe
Split Mengene Çenesi



Yüksek Mengene Çeneleri



Çift Mengene



Demet Kesim Çeneleri

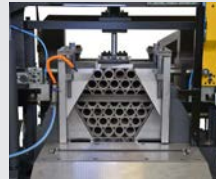





Lazer İşaretleyici





Teknik Özellikler

				
Kesme Kapasitesi	0°	820	850 x 820	820
	45°	480	480 x 820	480
Ana Motor	7,5 kW			
Hidrolik Motor	1,5 kW			
Soğutucu Motor	0,12 kW			
Kesme Hızları	20 - 100 m/min			
Şerit Testere Ölçüsü	8200 x 54 x 1,6 mm			
Malzeme Besleme Yüksekliği	585 mm			
Ebatlar	Uzunluk 3900 mm Genişlik 1200 mm		Yükseklik 2350 mm Ağırlık 3424 kg	

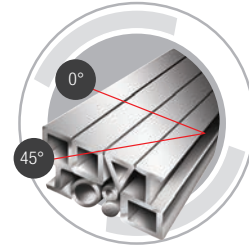

Talaş Konveyör



Hidrolik Üst Baskı



3 mt Motorlu Sehpa



3 mt Malzeme Sehpa



ILC Mikrosprey Soğutucu



2° Eğik Kafa



Döner Tabla



BMSY 810C

Sütunlu Yarı Otomatik Şerit Testere Makinası

Standartlar

Planet Redüktör
Hidrolik Mengene
Kesim Genişlik Ayar Kolu
Kapak Swich
Hassas Kesim Ayarı
Kontrol Paneli
Optik Yükseklik Ayarı
Hız kontrol cihazı
Talaş Firçası
Lineer Kızak
Dayama
Sap Boryağ Pompası
1,2 mt Malzeme Sehpa
Yükseklik Ayar Sensörü
Hidromekanik Şerit Germe
Hassas Basınç Ayarı
Hidrolik Şerit Germe (BMSY 820 C)

Opsiyonel

Yüksek Mengene Çeneleri
Çift Mengene
Demet Kesim Çeneleri
Lazer İşaretleyici
Talaş Konveyör
Hidrolik Üst Baskı
3 mt Motorlu Sehpa
3 mt Malzeme Sehpa
Mikrosprey Soğutucu
2° Eğik Kafa
Döner Tabla
Hidrolik Şerit Germe
Split Mengene Çenesi



Yüksek Mengene
Çeneleri



Çift Mengene



Demet Kesim Çeneleri



Lazer İşaretleyici



Talaş Konveyör





Hidrolik Üst Baskı





Teknik Özellikler

				
Kesme Kapasitesi	0°	810	850 x 810	810
	45°	480	480 x 810	480
Ana Motor	4 kW			
Hidrolik Motor	1,5 kW			
Soğutucu Motor	0,12 kW			
Kesme Hızları	20 - 100 m/min			
Şerit Testere Ölçüsü	8200x41x1,3 mm			
Malzeme Besleme Yüksekliği	585 mm			
Ebatlar	Uzunluk 3900 mm		Yükseklik 2350 mm	
	Genişlik 1200 mm		Ağırlık 3080 kg	

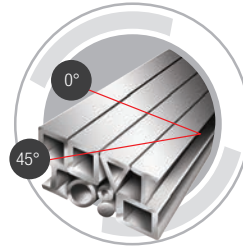

3 mt Motorlu Sehpa

3 mt Malzeme Sehpası

ILC Mikrosprey Soğutucu

2° Eğik Kafa

Döner Tabla

Hidrolik Şerit Germe

Split Mengene Çenesi



BMSY 650C - BMSY 570C BMSY 560C

Sütunlu Yarı Otomatik Şerit Testere Makinası

Standartlar

Planet Redüktör
Lineer Kızak
Kontrol Paneli
Dayama
Sap Boryağ Pompası
1,2 mt Malzeme Sehpa
Hidrolik Mengene
Hidromekanik Şerit Germe
Hız Kontrol Cihazı
Hassas Basınç Ayarı
Talaş Fırçası
Optik Yükseklik Ayarı

Opsiyonel

Çift Mengene
Paket Kesim Çeneleri
Hidrolik Şerit Germe
3 mt Motorlu sehpa
Lazer İşaretleyici
Talaş Konveyör
Hidrolik Üst Baskı
3 mt Malzeme Sehpa
Mikrosprey Soğutucu
Döner Tabla
2° Eğik Kafa

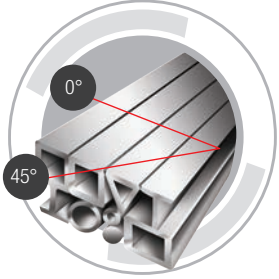

Çift Mengene



Demet Kesim Çeneleri



Hidrolik Şerit Germe











3 Mt Malzeme Sehpa







Lazer İşaretleyici



Teknik Özellikler

	BMSY 650C				BMSY 570C			
								
Kesme Kapasitesi	0°	650	1000 x 600	600	0°	570	600 x 570	570
Ana Motor	7,5 kW				7,5 kW			
Hidrolik Motor	4 kW				2,2 kW			
Soğutucu Motor	0,12 kW				0,2 kW			
Talaş Konveyör Motoru	0,25 kW				-			
Motorlu Talaş Fırçası	0,18 kW				-			
Kesme Hızları	20 - 100 m/min				20 - 100 m/min			
Şerit Testere Ölçüsü	8400 x 54 x 1,6 mm				7400 x 54 x 1,6 mm			
Malzeme Besleme Yüksekliği	650 mm				700 mm			
Ebatlar	Uzunluk 4750 mm Yükseklik 1970 mm		Genişlik 2500 mm Ağırlık 5300 kg		Uzunluk 3450 mm Yükseklik 1150 mm		Genişlik 2300 mm Ağırlık - kg	

Teknik Özellikler

	BMSY 560C			
				
Kesme Kapasitesi	0°	560	750 x 560	560
	45°	410	410 x 560	410
Ana Motor	4 kW			
Hidrolik Motor	1,1 kW			
Soğutucu Motor	0,12 kW			
Kesme Hızları	20 - 100 m/min			
Şerit Testere Ölçüsü	6000 x 41 x 1,3 mm			
Malzeme Besleme Yüksekliği	590 mm			
Ebatlar	Uzunluk 3400 mm	Genişlik 1000 mm	Yükseklik 2050 mm	Ağırlık 2045 kg



Talaş Konveyör



Hidrolik Üst Baskı



3 Metre Sehpa



Mikrosprey Soğutucu



Döner Tabla



2° Eğik Kafa



BMSY 460C

Sütunlu Yarı Otomatik Şerit Testere Makinası

Standartlar

Planet Redüktör
Şerit Testere Bıçağı 41
Lineer Kızak
Kontrol Paneli
Hidrolik Mengene
Hidromekanik Şerit Germe
Hız Kontrol Cihazı
SAP Boryağ Pompası
Kesim Genişlik Ayar Kolu
Mekanik Üst Baskı
Dayama
Basınç Ayarı
1,2 mt Malzeme Sehpa
Kapak Swich
Talaş Fırçası
Optik Yükseklik Ayarı

Opsiyonel

Talaş Konveyör
Hidrolik Şerit Germe
Mikrosprey Soğutucu
3 mt Malzeme Sehpa
2° Eğik Kafa



Yüksek Mengenerler



Çift Mengene



Demet Kesim Çeneleri



Hidrolik Üst Baskı



3 mt Motorlu Sehpa







Lazer İşaretleyici





Teknik Özellikler

				
Kesme Kapasitesi	0°	460	650 x 460	460
	45°	380	380 x 460	380
Ana Motor	4 kW			
Hidrolik Motor	0,55 kW			
Soğutucu Motor	0,12 kW			
Kesme Hızları	20 - 100 m/min			
Şerit Testere Ölçüsü	5200 x 41 x 1,3 mm			
Malzeme Besleme Yüksekliği	590 mm			
Ebatlar	Uzunluk 3100 mm		Yükseklik 1800 mm	
	Genişlik 1000 mm		Ağırlık 1520 kg	

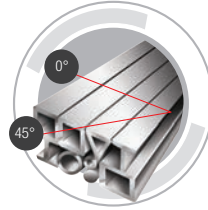

Talaş Konveyör



3 Mt Malzeme Sehpası



Mikrosprey Soğutucu



Hidrolik Şerit Germe



2° Eğik Kaşa



Döner Tabla



Split Mengene Çenesi



BMSY 360C - BMSY 325C

Sütunlu Yarı Otomatik Şerit Testere Makinası

Standartlar

Planet Redüktör
Şerit Testere Bıçağı 41
Lineer Kızak
Kontrol Paneli
Hidrolik Mengene
Hidromekanik Şerit Germe
Hız Kontrol Cihazı
SAP Boryağ Pompası

Kesim Genişlik Ayar Kolu
Mekanik Üst Baskı
Dayama
Basınç Ayarı
1,2 mt Malzeme Sehpa
Kapak Swich
Talaş Fırçası
Optik Yükseklik Ayarı

Opsiyonel

Talaş Konveyör
Hidrolik Şerit Germe
Mikrosprey Soğutucu
3 mt Malzeme Sehpa
2° Eğik Kafa

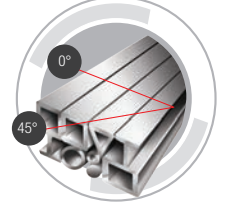

Yüksek Mengeneler



Çift Mengene



Demet Kesim Çeneleri



Hidrolik Üst Baskı











3 mt Motorlu Sehpa



Lazer İşaretleyici



Teknik Özellikler

	BMSY 360C				BMSY 325C			
								
Kesme Kapasitesi	0°	380	520 x 380	380	0°	325	450 x 325	325
	45°	300	300 x 380	300	45°	250	250 x 325	250
Ana Motor	3 kW				2,2 kW			
Hidrolik Motor	0,55 kW				0,55 kW			
Soğutucu Motor	0,12 kW				0,12 kW			
Cutting Speeds	20 - 100 m/min				20 - 100 m/min			
Kesme Hızları	4800 x 34 x 1,1 mm				4160 x 34 x 1,1 mm			
Malzeme Besleme Yüksekliği	590 mm				580 mm			
Ebatlar	Uzunluk 2850 mm Genişlik 930 mm		Yükseklik 1660 mm Ağırlık 1330 kg		Uzunluk 2150 mm Genişlik 860 mm		Yükseklik 1500 mm Ağırlık 1010 kg	

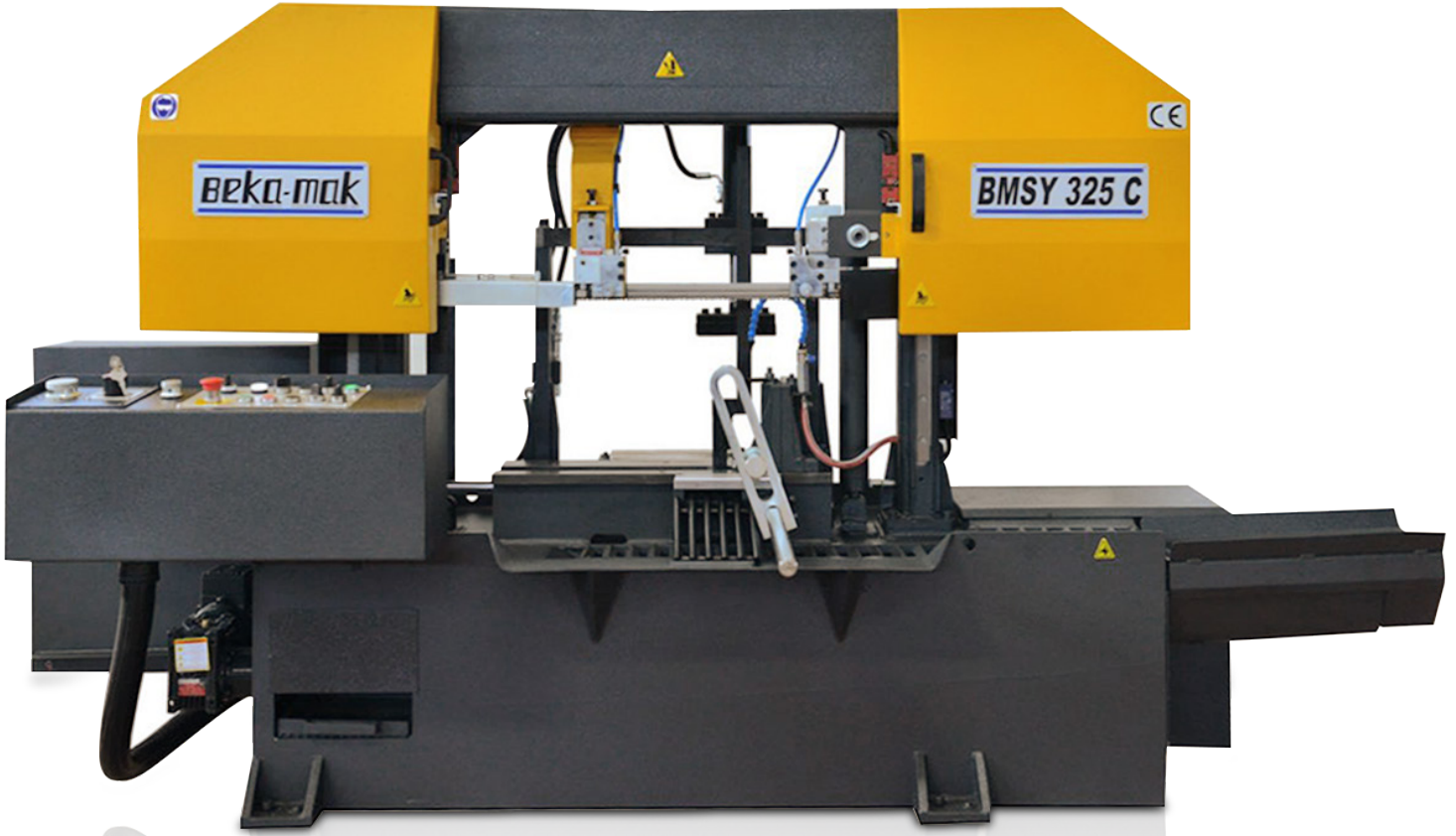
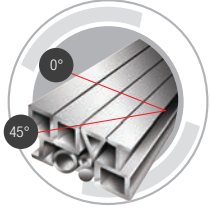

Talaş Konveyör

3 Mt Malzeme Sehpası

Mikrosprey Soğutucu

Hidrolik Şerit Germe

2° Eğik Kaşa

Döner Tabla

Split Mengene Çenesi

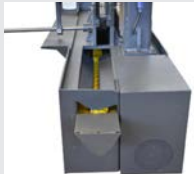

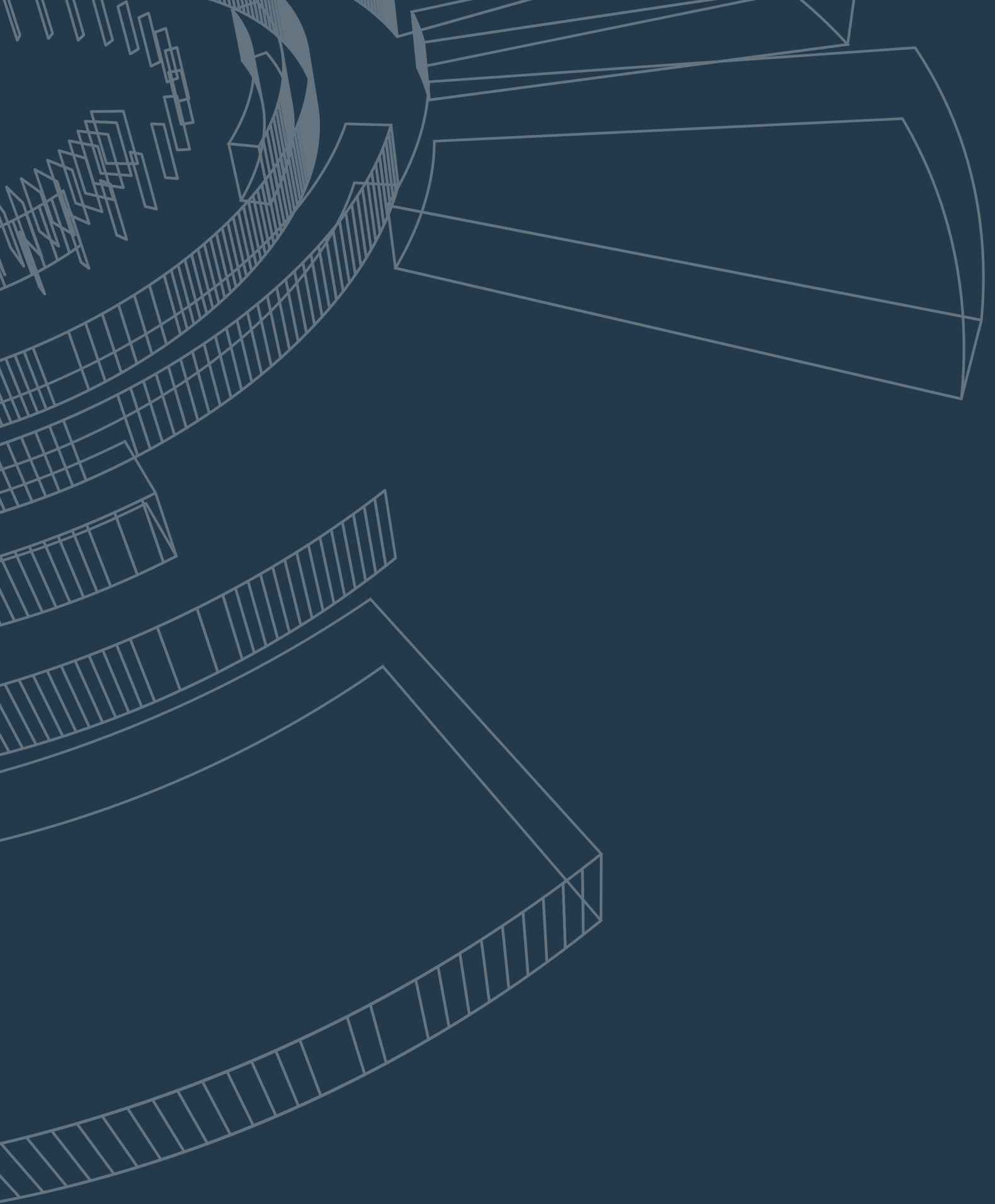

SÜTUNLU TAM OTOMATİK ŞERİT TESTERE MAKİNA MODELLERİ

BMSO 820C - BMSO 810C
BMSO 560C - BMSO 460C
BMSO 360C - BMSO 325C



Model	Sayfa
BMSO 820C	68
BMSO 810C	70
BMSO 560C	72
BMSO 460C	73
BMSO 360C	74
BMSO 325C	75

BMSO 820C

Sütunlu Tam Otomatik Şerit Testere Makinası

Standartlar

Hidrolik Şerit Germe
Hız Kontrol Cihazı
Hidrolik Mengene
Hassas Basınç Ayarı
1,2 mt Malzeme Sehpa
Lineer Kızak
Şerit Testere Bıçağı 54
Optik Yükseklik Ayarı

Talaş Fırçası
Kesim Genişlik Ayar Kolu
Dayama
Kontrol Paneli
SAP Boryağ Pompası
Planet Redüktör
Kapak Swich

Opsiyonel

Talaş Konveyoru
Mikrosprey Soğutucu
3 Mt Malzeme Sehpa
Lazer İşaretleyici



Teknik Özellikler

				
Kesme Kapasitesi	0°	820	850 x 820	820
Ana Motor	7,5 kW			
Hidrolik Motor	1,5 kW			
Sürücü Motor	0,55 kW			
Soğutucu Motor	0,12 kW			
Kesme Hızları	20 - 100 m/min			
Şerit Testere Ölçüsü	8200 x 54 x 1,6 mm			
Malzeme Besleme Yüksekliği	585 mm			
Ebatlar	Uzunluk 3900 mm Genişlik 2350 mm		Yükseklik 1200 mm Ağırlık 3424 kg	

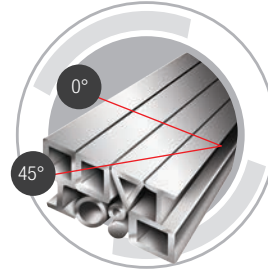

Talaş Konveyörü

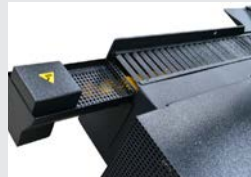

Mikrosprey Soğutucu

3 Mt Malzeme Sehpası



Lazer İşaretleyici



BMSO 810C

Sütunlu Tam Otomatik Şerit Testere Makinası

Standartlar

Hidrolik Şerit Germe
Hız Kontrol Cihazı
Hidrolik Mengene
Hassas Basınç Ayarı
1,2 mt Malzeme Sehpası
Lineer Kızak
Şerit Testere Bıçağı 54
Optik Yükseklik Ayarı

Talaş Fırçası
Kesim Genişlik Ayar Kolu
Dayama
Kontrol Paneli
SAP Boryağ Pompası
Planet Redüktör
Kapak Swich

Opsiyonel

Talaş Konveyoru
Mikrosprey Soğutucu
3 Mt Malzeme Sehpası
Lazer İşaretleyici

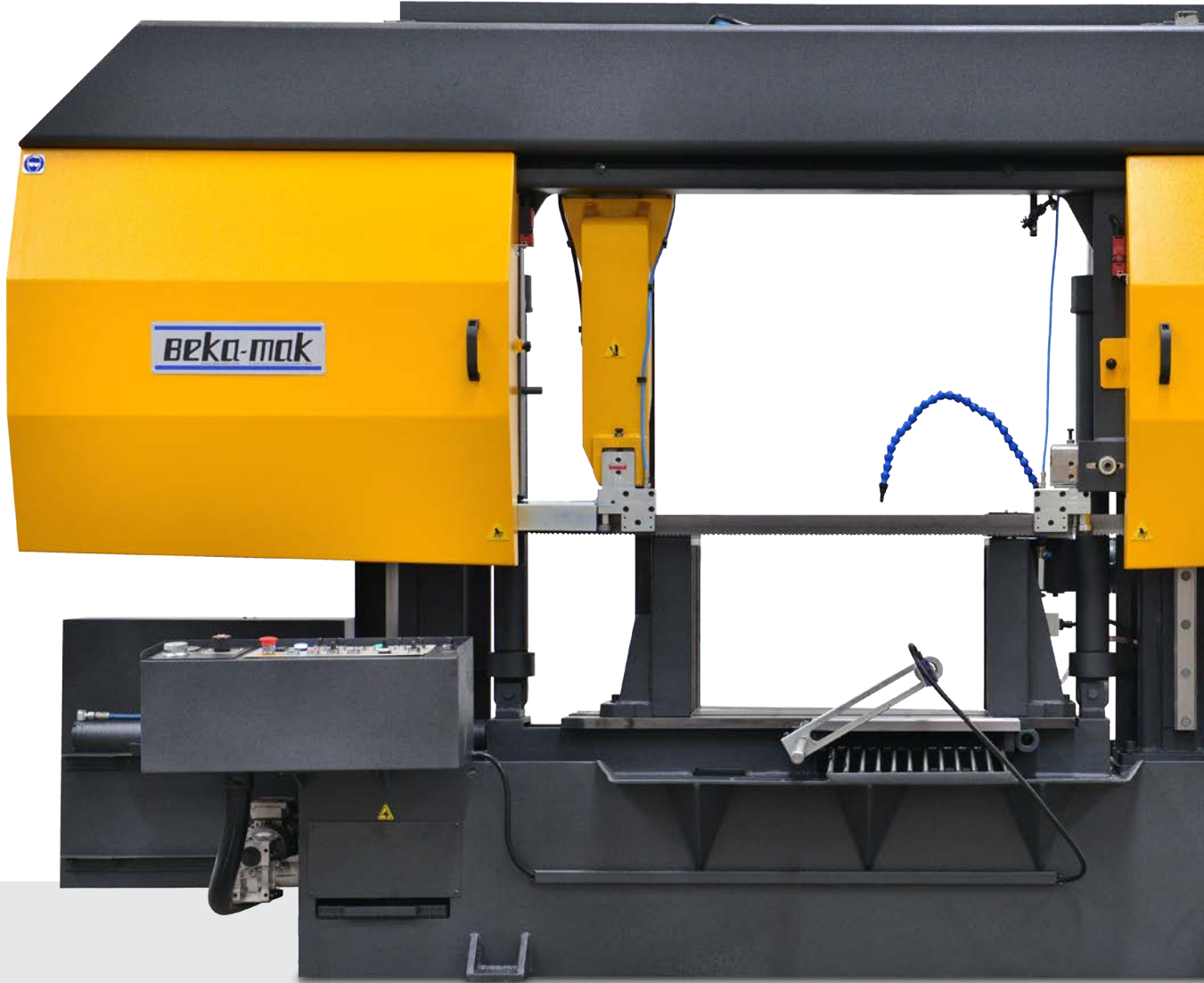



Teknik Özellikler

				
Kesme Kapasitesi	0°	810	850 x 810	810
Ana Motor	4 kW			
Hidrolik Motor	1,5 kW			
Sürücü Motor	0,55 kW			
Soğutucu Motor	0,12 kW			
Kesme Hızları	20 - 100 m/min			
Şerit Testere Ölçüsü	8200 x 41 x 1,3 mm			
Malzeme Besleme Yüksekliği	585 mm			
Ebatlar	Uzunluk 3900 mm Genişlik 1200 mm		Yükseklik 2350 mm Ağırlık 3080 kg	

Talaş Konveyoru

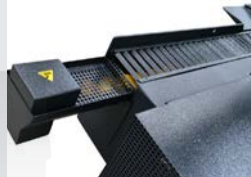

Mikrosprey Soğutucu



3 Mt Malzeme Sehpası



Lazer İşaretleyici



BMSO 560C - BMSO 460C

Sütunlu Tam Otomatik Şerit Testere Makinası

Standartlar

Planet Redüktör
Lineer Kızak
Mekanik Üst Baskı
Hız Kontrol Cihazı
Şerit Testere Bıçağı 41
Dayama
Hidrolik Mengene
Kapak Swich

Hassas Basınç Ayarı
Hidromekanik Şerit Germe
SAP Boryağ Pompası
Kontrol Paneli
Kesim Genişlik Ayar Kolu
1,2 mt Malzeme Sehpa
Optik Yükseklik Ayarı
Talaş Fırçası

Opsiyonel

Lazer İşaretleyici
Hidrolik Şerit Germe
Talaş Konveyoru
3 mt Motorlu Sehpa
Mikrosprey Soğutucu

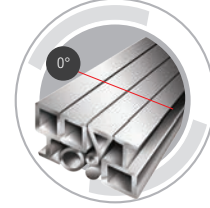

OPSIYONEL

Lazer İşaretleyici



Talaş Konveyoru



Hidrolik Şerit Germe



Mikrosprey Soğutucu





3 mt Motorlu Sehpa



2° Eğik Kafa



Teknik Özellikler

	BMSO 560 C				BMSO 460 C			
								
Kesme Kapasitesi	0°	560	570 x 560	560	0°	460	470 x 460	460
Ana Motor	4 kW				4 kW			
Hidrolik Motor	1,1 kW				0,55 kW			
Sürücü Motor	0,55 kW				0,55 kW			
Soğutucu Motor	0,12 kW				0,12 kW			
Talaş Konveyör Motoru	0,25 kW				0,25 kW			
Kesme Hızları	20 - 100 m/min				20 - 100 m/min			
Şerit Testere Ölçüsü	6000 x 41 x 1,3 mm				5200 x 41 x 1,3 mm			
Malzeme Besleme Yüksekliği	590 mm				590 mm			
Ebatlar	Uzunluk 500 mm Genişlik 1050 mm		Yükseklik 2050 mm Ağırlık 2242 kg		Uzunluk 3100 mm Genişlik 1000 mm		Yükseklik 1800 mm Ağırlık 1655 kg	

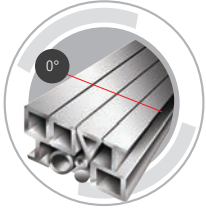

BMSO 360C - BMSO 325C

Sütunlu Tam Otomatik Şerit Testere Makinası

Standartlar

Şerit Testere Bıçağı 34'lük
Kesim Genişlik Ayar Kolu
Hız Kontrol Cihazı
Kapak Swich
Hidromekanik Şerit Germe
Talaş Fırçası
Lineer Kızak
Dayama
Hidrolik Mengene
Kontrol Paneli
Mekanik Üst Baskı
Yükseklik Ayar Sensörü
Hassas Basınç Ayarı
SAP Boryağ Pompası
1,2 Metre Malzeme Sehpa

Opsiyonel

Talaş Konveyoru
3 Metre Malzeme Sehpa
Hidrolik Şerit Germe
Mikrosprey Soğutucu

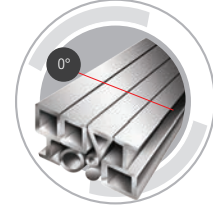

Talaş Konveyoru

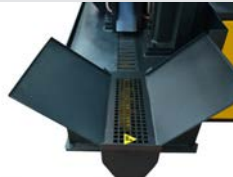

3 Mt Motorlu Sehpa











Hidrolik Şerit Germe



Mikrosprey Soğutucu



Teknik Özellikler

	BMSO 360C				BMSO 325C			
								
Kesme Kapasitesi	0°	380	430 x 380	380	0°	325	350x325	325
Ana Motor	3 kW				2,2 kW			
Hidrolik Motor	0,55 kW				0,55 kW			
Sürücü Motor	0,25 kW				0,25 kW			
Soğutucu Motor	0,12 kW				0,12 kW			
Talaş Konveyör Motoru	0,25 kW				-			
Kesme Hızları	20 - 100 m/min				20 - 100 m/min			
Şerit Testere Ölçüsü	4800 x 34 x 1,1 mm				4160 x 34 x 1,1 mm			
Malzeme Besleme Yüksekliği	590 mm				580 mm			
Ebatlar	Uzunluk 2850 mm Genişlik 930 mm		Yükseklik 1660 mm Ağırlık 1330 kg		Uzunluk 2450 mm Genişlik 900 mm		Yükseklik 1500 mm Ağırlık 1030 kg	

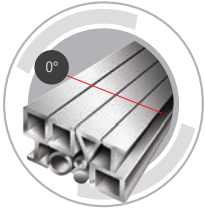

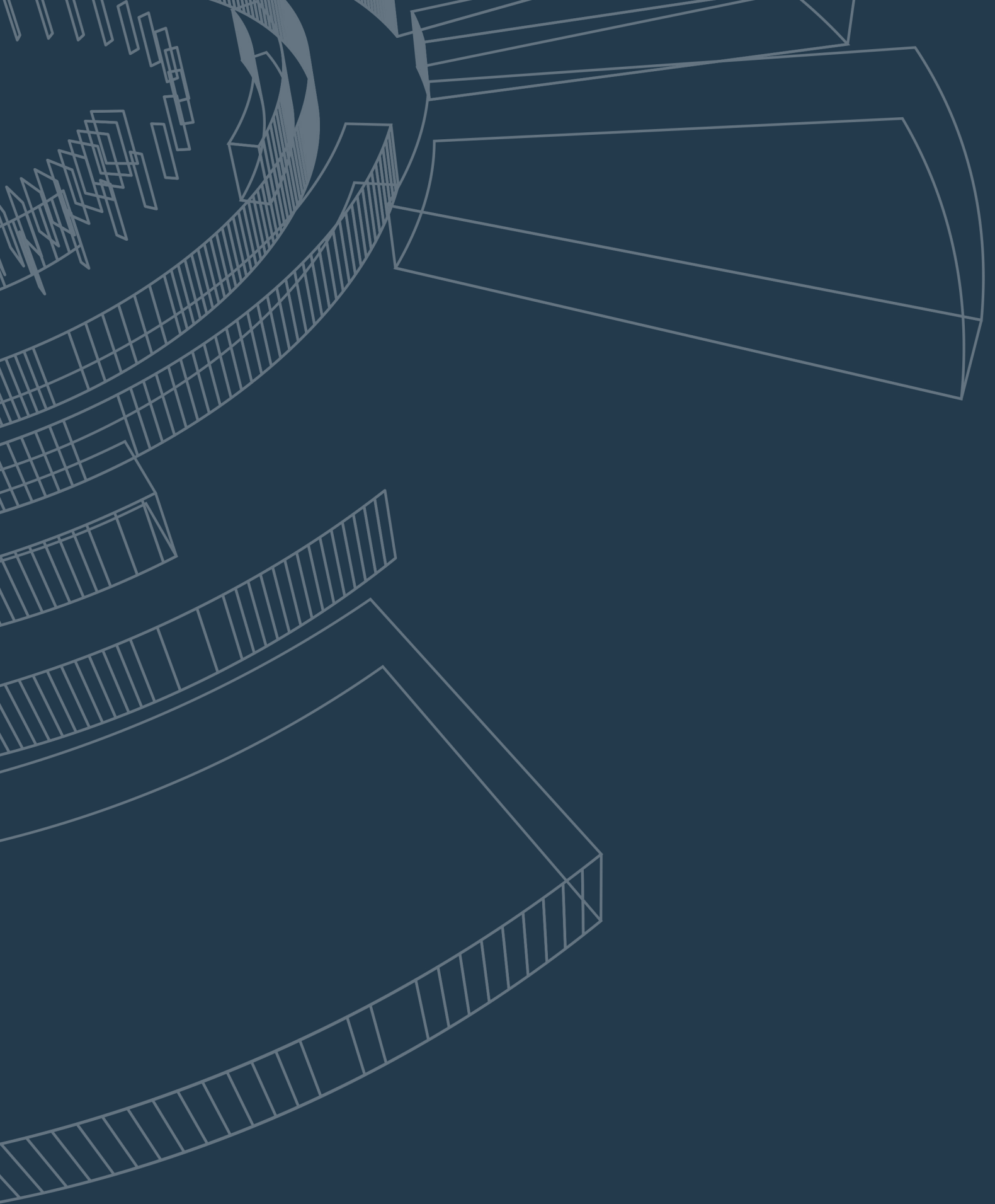

TEK TARAF AÇILI ŞERİT TESTERE MAKİNA MODELLERİ

BMSY 810 CGH - BMSY 540 CGH - BMSY 440 CGH
BMSY 360 CGH - BMSY 325 CGH
BMSY 320 GL - BMSY 320 G - BMS 320 G



Model	Sayfa
BMSY 810 CGH	78
BMSY 540 CGH	80
BMSY 440 CGH	82
BMSY 360 CGH	83
BMSY 325 CGH	84
BMSY 320 GL	85
BMSY 320 G	86
BMS 320 G	87

BMSY 810 CGH

Tek Taraf Açılı Şerit Testere Makina Modelleri

Standartlar

Planet Redüktör
Dijital Açı Göstergesi
Şerit Testere 41
Hidrolik Mengene
Hidrolik Açılı Sabitleme
Hız Kontrol Cihazı
Hidromekanik Şerit Germe
Kapak Switch
Kesim Genişlik Ayar Kolu
Lineer Kızak
Hassas Basınç
Kontrol Paneli
SAP Boryağ Pompası
3° Eğik Kafa
Talaş Fırçası

Opsiyonel

Hidrolik Şerit Germe
Hidrolik Üst Baskı
Lazer İşaretleyici
Talaş Konveyörü
3 mt Motorlu Sehpa
3 mt Malzeme Sehpası
Mikrosprey Soğutucu





Teknik Özellikler

				
Kesme Kapasitesi	0°	810	750 x 910	750
	30°	760	740 x 750	740
	45°	600	750 x 600	600
	60°	360	750 x 360	360
Ana Motor	4 kW			
Hidrolik Motor	1,5 kW			
Soğutucu Motor	0,12 kW			
Talaş Konveyör Motoru	0,25 kW			
Kesme Hızları	20 - 100 m/min			
Şerit Testere Ölçüsü	8200 x 41 x 1,3 mm			
Malzeme Besleme Yüksekliği	725 mm			
Ebatlar	Uzunluk 4020 mm Genişlik 1600 mm Yükseklik 2450 mm Ağırlık 3970 kg			

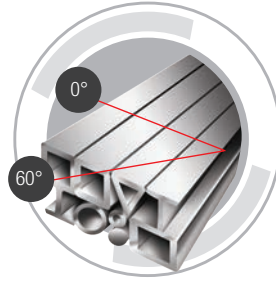

Mikrosprey Soğutucu

Hidrolik Şerit Germe

Hidrolik Üst Baskı

Lazer İşaretleyici

Talaş Konveyörü

3 mt Motorlu Sehpa

3 mt Malzeme Sehpa



BMSY 540 CGH

Tek Taraf Açılı Şerit Testere Makinası

Standartlar

Planet Redüktör
Digital açı göstergesi
Hız Kontrol Cihazı
Lineer Kızak
Hassas Basınç
Hidrolik Açı Sabitleme
Kumando Panosu
Şerit Testere 41
Hidrolik Mengene
Kesim Genişlik Ayar Kolu
Hidromekanik Şerit Germe
Kapak Swich
Talaş Fırçası
3° Eğik Kafa
Optik Yükseklik Ayarı

Opsiyonel

Hidrolik Üst Baskı
Hidrolik Şerit Germe
Lazer İşaretleyici
3 mt Motorlu sehpa
3 mt Malzeme Sehpa
Mikrosprey Soğutucu





Teknik Özellikler

				
Kesme Kapasitesi	0°	540	750 x 540	540
	30°	540	600 x 540	540
	45°	510	450 x 540	450
	60°	270	250 x 540	250
Ana Motor	4 kW			
Hidrolik Motor	1,1 kW			
Soğutucu Motor	0,12 kW			
Kesme Hızları	20 - 100 m/min			
Şerit Testere Ölçüsü	6000 x 41 x 1,3 mm			
Malzeme Besleme Yüksekliği	695 mm			
Ebatlar	Uzunluk 3000 mm Genişlik 1300 mm Yükseklik 2150 mm Ağırlık 2445 kg			

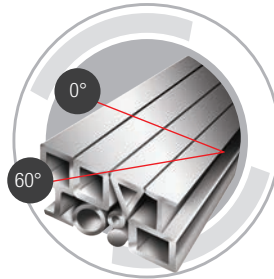

Hidrolik Üst Baskı



Hidrolik Şerit Germe



Lazer İşaretleyici



3 Mt Motorlu Sehpa



3 mt Malzeme Sehpa



Mikrosprey Soğutucu



BMSY 440 CGH - BMSY 360 CGH

Tek Taraf Açılı Şerit Testere Makinası

Standartlar

Planet Redüktör
Lineer Kızak
Hidromekanik Şerit Germe
Kesim Genişlik Ayar Kolu
Talaş Fırçası
Dijital Açı Göstergesi
Hız Kontrol Cihazı
Kumanda Panosu
Hassas Basınç
Hidrolik Açılı Sabitleme

Şerit Testere Bıçağı 41
SAP Boryağ Pompası
Kapak Swich
Optik Yükseklik Ayarı
3° Eğik Kafa
Hidrolik Mengene
Lineer Malzeme Genişlik Kolu
Kumanda Panosu
Şerit Testere 34

Opsiyonel

Mikrosprey Soğutucu
Hidrolik Şerit Germe
Lazer İşaretleyici
3 Mt Motorlu Sehpa
3 mt Malzeme Sehpası
Talaş Konveyoru
Hidrolik Üst Baskı

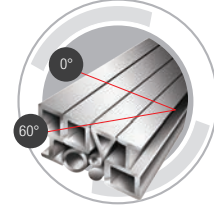

Mikrosprey Soğutucu

Hidrolik Şerit Germe

Lazer İşaretleyici

3 Mt Motorlu Sehpa









3 Mt Malzeme Sehpası

Talaş Konveyoru

Hidrolik Üst Baskı



Teknik Özellikler

	BMSY 440 CGH				BMSY 360 CGH			
								
Kesme Kapasitesi	0°	450	695 x 425	425	0°	360	700 x 360	360
	30°	450	560 x 425	425	30°	360	590 x 360	360
	45°	430	430x 425	425	45°	360	450 x 360	360
	60°	320	260 x 425	290	60°	325	280 x 360	290
Ana Motor	4 kW				3 kW			
Hidrolik Motor	0,55 kW				0,55 kW			
Soğutucu Motor	0,12 kW				0,12 kW			
Kesme Hızları	20 - 100 m/min				20 - 100 m/min			
Şerit Testere Ölçüsü	5400 x 41 x 1,3 mm				5200 x 34 x 1,1 mm			
Malzeme Besleme Yüksekliği	690 mm				690 mm			
Ebatlar	Uzunluk 2850 mm		Yükseklik 1800 mm		Uzunluk 2850 mm		Yükseklik 1820 mm	
	Genişlik 1300 mm		Ağırlık 1630 kg		Genişlik 1300 mm		Ağırlık 1460 kg	

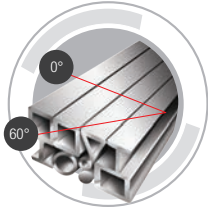

BMSY 325 CGH - BMSY 320 GL

Tek Taraf Açılı Şerit Testere Makinası

Standartlar

Lineer Kızak
Hassas Basınç
Şerit Testere 34
SAP Boryağ Pompası
Kapak Swich
Hidromekanik Şerit Germe
Talaş Fırçası
Hidrolik Mengene
Optik Yükseklik Ayarı
Kesim Genişlik Ayar Kolu

2° Eğik Kafa
Hız Kontrol Cihazı
Dijital Açık Göstergesi
Hidrolik Açık Sabitleme
Kontrol Paneli
Yükseklik Ayar Swich
Dayama
Açık Ayarlama Göstergesi
1,2 Mt Malzeme Sehpa

Opsiyonel

ILC Mikrosprey
Hidrolik Üst Baskı
Hidrolik Şerit Germe
Talaş Konveyoru
Lazer İşaretleyici
3 Metre Malzeme Sehpa
3 Mt Motorlu Sehpa
Hassas Basınç

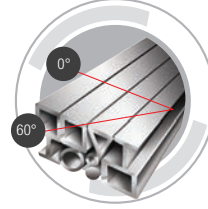

Mikrosprey Soğutucu



Hidrolik Üst Baskı



Hidrolik Şerit Germe



Talaş Konveyoru



Lazer İşaretleyici





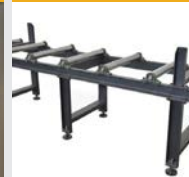

3 Mt Malzeme Sehpa



3 Mt Motorlu Sehpa



Teknik Özellikler

	BMSY 325 CGH				BMSY 320 GL			
								
Kesme Kapasitesi	0°	325	400 x 320	320	0°	320	610 x 320	320
	30°	325	360 x 320	320	30°	260	280 x 200	225
	45°	305	270 x 320	270	45°	320	355 x 320	320
	60°	190	180 x 240	180	60°	320	510 x 320	320
	-	-	-	-	75°	320	580 x 320	320
Ana Motor	2,2 kW				2,2 kW			
Hidrolik Motor	0,55 kW				0,37 kW			
Soğutucu Motor	0,12 kW				0,12 kW			
Kesme Hızları	20 - 100 m/min				20 - 100 m/min			
Şerit Testere Ölçüsü	4380 x 34 x 1,1 mm				4160 x 34 x 1,1 mm			
Malzeme Besleme Yüksekliği	640				740 mm			
Ebatlar	Uzunluk 2100 mm Genişlik 1300 mm		Yükseklik 1600 mm Ağırlık 1185 kg		Uzunluk 2100 mm Genişlik 1200 mm		Yükseklik 1350 mm Ağırlık 1195 kg	

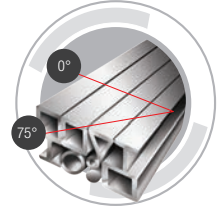

Hidrolik Üst Baskı



Mikrosprey Soğutucu



Hidrolik Şerit Germe



Hassas Basınç



3 Mt Malzeme Sehpası



BMSY 320 G - BMS 320 G

Tek Taraf Açılı Şerit Testere Makinası - Tek Taraf Açılı Manuel Şerit Testere Makinası

Standartlar







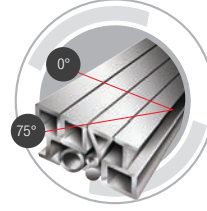

Kapak Swich
Açı Ayarlama Göstergesi
Yükseklik Ayar Swich
Kontrol Paneli
Dayama
SAP Boryağ Pompası
Hidrolik Mengene
Hız Kontrol Cihazı
Şerit Testere 27
Planet Redüktör
Hidromekanik Şerit Germe
1,2 Mt Malzeme Sehpa
Talaş Fırçası

Opsiyonel

Hidrolik Üst Baskı
ILC Microspray Device
Hidrolik Şerit Germe
Hassas Basınç
3 Mt Malzeme Sehpa



Teknik Özellikler

	BMSY 320 G				BMS 320 G			
								
Kesme Kapasitesi	0°	320	350 x 320	320	0°	320	350 x 320	320
	30°	160	150 x 150	150	30°	160	150 x 150	150
	45°	260	250 x 180	180	45°	260	250 x 180	180
	60°	300	300 x 200	250	60°	300	300 x 200	250
	75°	320	350 x 200	300	75°	320	350 x 200	300
Ana Motor	1,5 kW				1,5 kW			
Hidrolik Motor	0,37 kW				-			
Soğutucu Motor	0,12 kW				0,12 kW			
Kesme Hızları	20 - 100 m/min				20 - 100 m/min			
Şerit Testere Ölçüsü	3660 x 27 x 0,9 mm				36600 x 34 x 1,1 mm			
Malzeme Besleme Yüksekliği	740 mm				740 mm			
Ebatlar	Uzunluk 1900 mm Genişlik 1200 mm		Yükseklik 1350 mm Ağırlık 1015 kg		Uzunluk 1900 mm Genişlik 1200 mm		Yükseklik 1350 mm Ağırlık 960 kg	

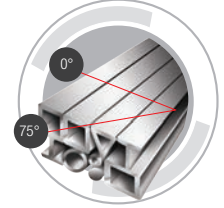

Hidrolik Üst Baskı



Mikrosprey Soğutucu



Hidrolik Şerit Germe



Hassas Basınç



3 Mt Malzeme Sehpası



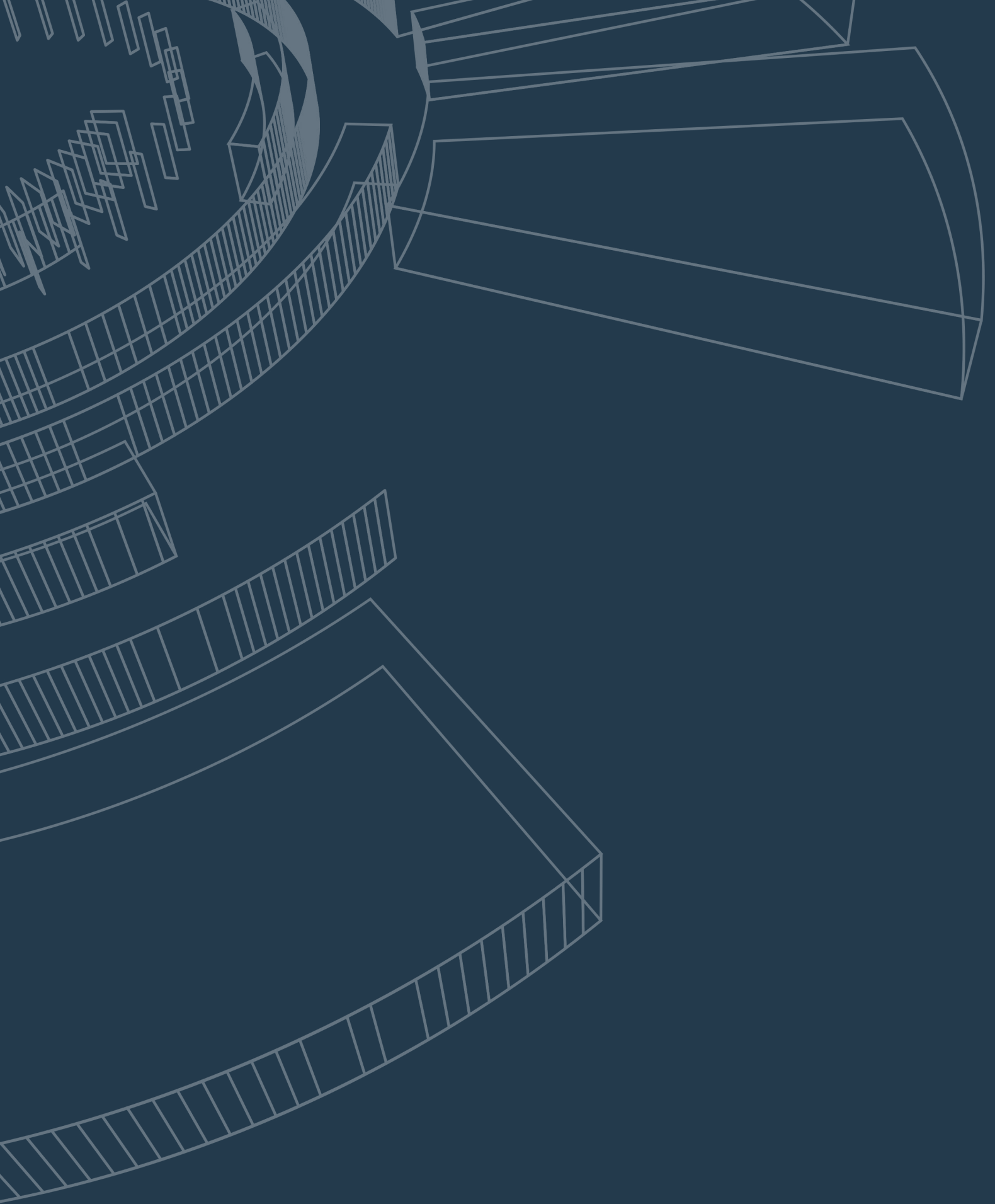

ÇİFT TARAF AÇILI MAFSALLI ŞERİT TESTERE MAKİNA MODELLERİ

BMSY 440 DGH / BMSY 440 DGH NC
BMSY 360 DGH - BMSY 360 DGH ECO
BMSY 270 DGH - BMSY 270 DG - BMS 270 DG
BMSY 230 DGH - BMSY 230 DG - BMS 230 DG

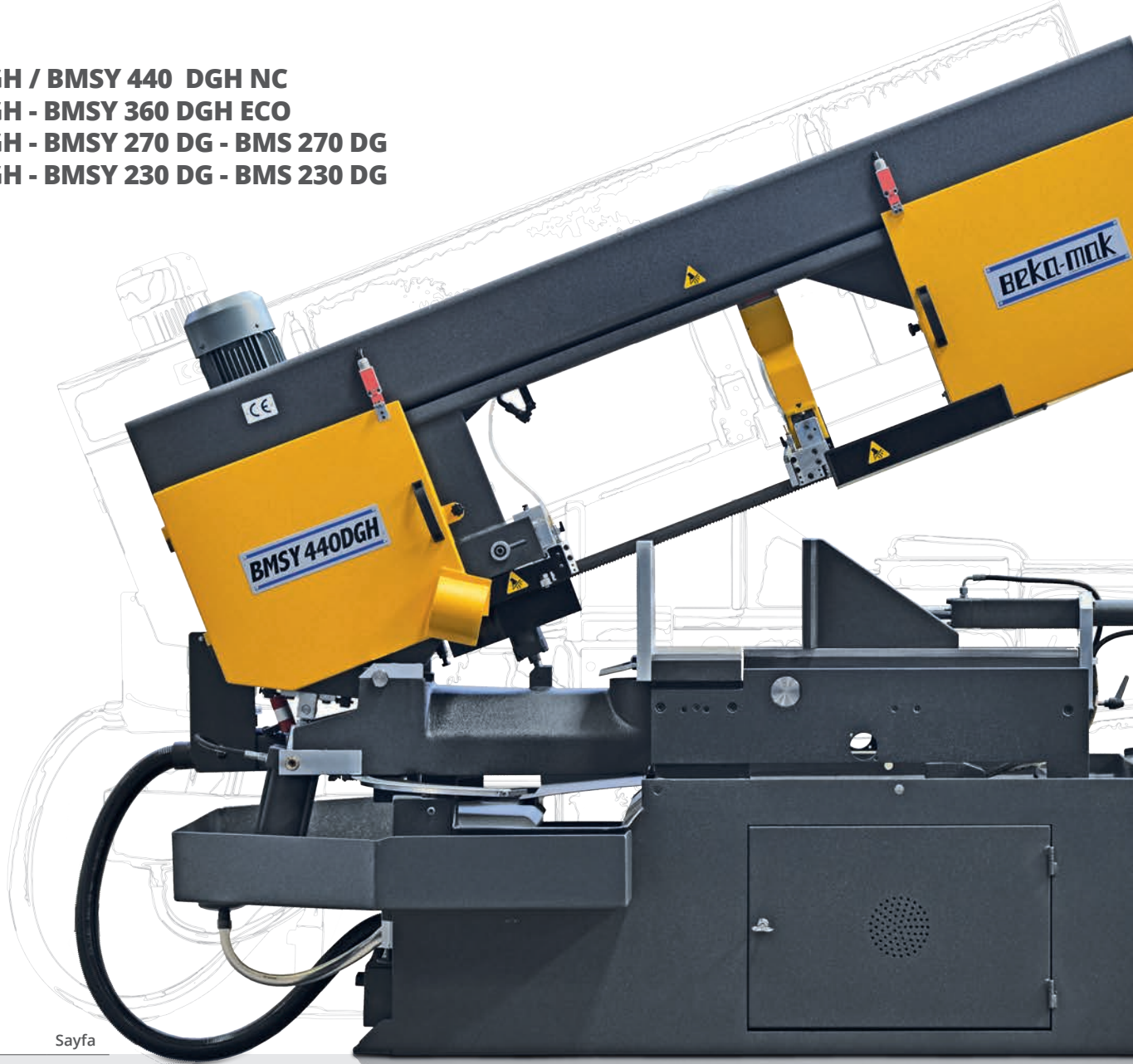

Model	Sayfa
BMSY 440 DGH / DGH NC	90
BMSY 360 DGH	92
BMSY 360 DGH ECO	93
BMSY 270 DGH	94
BMSY 270 DG	94
BMS 270 DG	95
BMSY 230 DGH	96
BMSY 230 DG	96
BMS 230 DG	97

BMSY 440 DGH / DGH NC

Çift Tarafa Açılı Mafsallı Şerit Testere Makinası

Standartlar







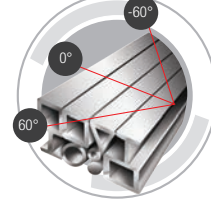

Şerit Testere Bıçağı 34
Kumando Panosu
Talaş Firçası
Hız Kontrol Cihazı
Kapak Swich
Hidro Mekanik Şerit Germe
Lineer Kızaklı kol
Hidrolik Mengene
Vibrasyon Önleyici Silindir
Yükseklik Ayar Sensörü
Planet Redüktör
SAP Boryağ Pompası
Hidrolik Mengene Gezdirme Sistemi
Hassas Basınç Ayarı
Nc Kontrol Paneli
Açıya Gidiş Sireni

Opsiyonel

Hidrolik Şerit Germe
Yükseklik Ayar Sensörü
3 Mt Motorlu Sehpa
3 mt Malzeme Sehpası
Lazer İşaretleyici
Mikrosprey Soğutucu



Teknik Özellikler

	BMSY 440 DGH				BMSY 440 DGH NC			
								
Kesme Kapasitesi	0°	-	440 x 610	440	0°	440	440 x 610	440
	30°	440	440 x 500	440	30°	440	440 x 500	440
	45°	410	440 x 410	410	45°	410	440 x 410	410
	60°	320	440 x 250	250	60°	320	440 x 250	250
	-30°	440	440 x 500	440	-30°	440	440 x 500	440
	-45°	410	440 x 410	410	-45°	410	440 x 410	410
	-60°	320	440 x 285	285	-60°	320	440 x 285	285
Ana Motor	3 kW				3 kW			
Hidrolik Motor	0,55 kW				0,55 kW			
Soğutucu Motor	0,12 kW				0,12 kW			
Kesme Hızları	20 - 100 m/min				20 - 100 m/min			
Şerit Testere Ölçüsü	5000 x 34 x 1,1 mm				5200 x 34 x 1,1 mm			
Malzeme Besleme Yüksekliği	860 mm				860 mm			
Ebatlar	Uzunluk 2750 mm Genişlik 1210 mm		Yükseklik 1870 mm Ağırlık 1195		Uzunluk 2800 mm Genişlik 1210 mm		Yükseklik 1870 mm Ağırlık 1640 kg	

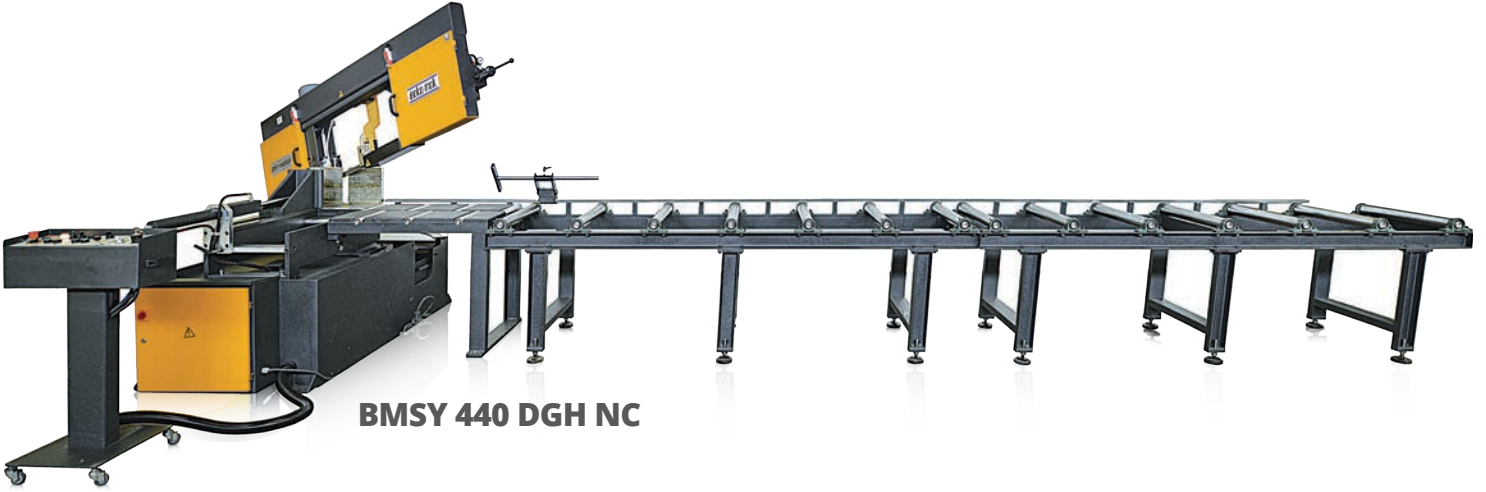

BMSY 440 DGH NC

Hidrolik Şerit Germe



Yükseklik Ayar Sensörü



3 Mt Motorlu Sehpa



3 mt Malzeme Sehpa



Lazer İşaretleyici



Mikrosprey Soğutucu



BMSY 360 DGH - BMSY 360 DGH ECO

Çift Tarafa Açılı Mafsallı Şerit Testere Makinası

Standartlar

Şerit Testere Bıçağı 34
Hassas Basınç Ayarı
Hız Kontrol Cihazı
Talaş Fıçası
Kapak Swich
Hidro Mekanik Şerit Germe
Lineer Kızaklı kol
Hidrolik Mengene

Vibrasyon Önleyici Silindir
Kontrol Paneli
Planet Redüktör
SAP Boryağ Pompası
Yükseklik Ayar Swich
Dijital Açık Göstergesi
Hareketli Kumanda

Opsiyonel

Hidrolik Şerit Germe
Yükseklik Ayar Sensörü
3 Mt Motorlu Sehpa
3 mt Malzeme Sehpa
Lazer İşaretleyici
Mikrosprey Soğutucu

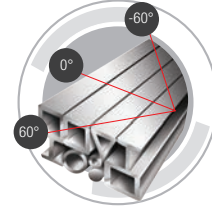

Hidrolik Şerit Germe



Yükseklik Ayar Sensörü



3 Mt Motorlu Sehpa



3 mt Malzeme Sehpa











Lazer İşaretleyici



Mikrosprey Soğutucu



Teknik Özellikler

	BMSY 360 DGH				BMSY 360 DGH ECO			
								
Kesme Kapasitesi	0°	360	610 x 360	360	0°	360	510 x 360	360
	30°	360	610 x 360	360	30°	360	510 x 360	360
	45°	360	490 x 360	360	45°	360	390 x 360	360
	60°	340	300 x 360	300	60°	200	200 x 360	200
	-30°	360	610 x 360	360	-30°	360	510 x 360	360
	-45°	360	490 x 360	360	-45°	360	390 x 360	360
	-60°	360	360 x 360	360	-60°	260	260 x 360	260
Ana Motor	3 kW				3 kW			
Hidrolik Motor	0,55 kW				0,37 kW			
Soğutucu Motor	0,12 kW				0,12 kW			
Kesme Hızları	20 - 100 m/min				20 - 100 m/min			
Şerit Testere Ölçüsü	5000 x 34 x 1,1 mm				4800 x 34 x 1,1 mm			
Malzeme Besleme Yüksekliği	860 mm				860 mm			
Ebatlar	Uzunluk 2750 mm Genişlik 1210 mm		Yükseklik 1870 mm Ağırlık 1470		Uzunluk 2800 mm Genişlik 1210 mm		Yükseklik 1870 mm Ağırlık 1450 kg	

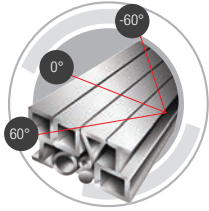

BMSY 270 DGH - BMSY 270 DG

Çift Tarafa Açılı Mafsallı Şerit Testere Makinası
DGH - Hidrolik Mengene Standart

Standartlar

Şerit Testere Bıçağı 27
Yükseklik Ayar Swich
Planet Redüktör
Sap Boryağ Pompası
Ayak Pedalı
Kumando Panosu
Dayama
Hidromekanik Şerit Germe
Talaş Fırçası
Kapak Swich

Opsiyonel

3 Mt Malzeme Sehpa
Hız Kontrol Cihazı
Mikrosprey Soğutucu

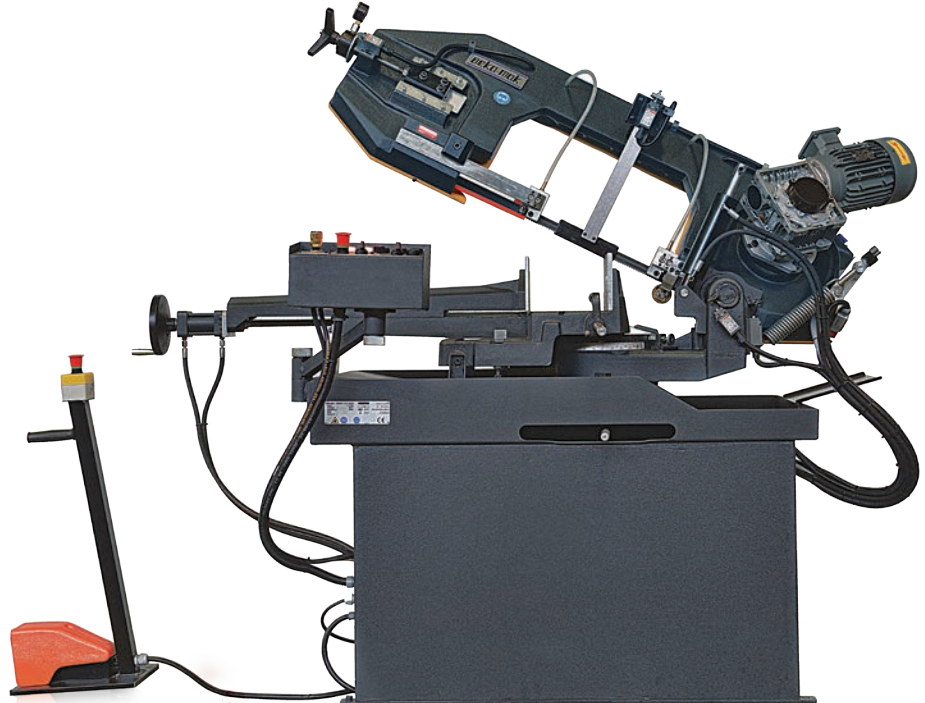

BMSY 270 DGH



BMSY 270 DG

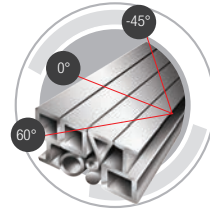

BMS 270 DG

Çift Tarafa Açılı Manuel Mafsallı Şerit Testere Makinası

Standartlar

Hidromekanik Şerit Germe
Mengene
Siti Redüktör
Şerit Testere Bıçağı 27
Hız Kontrol Cihazı
Talaş Fırçası
Kapak Swich
Dayama
SAP Boryağ pompası
Kontrol Panel

Opsiyonel

3 Mt Malzeme Sehpa
Mikrosprey Soğutucu

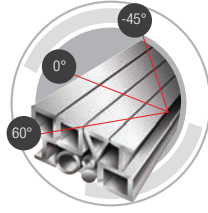

Teknik Özellikler

	BMSY 270 DGH				BMSY 270 DG				BMS 270 DG			
	△	○	□	□	△	○	□	□	△	○	□	□
Kesme Kapasitesi	0°	270	350x220	270	0°	270	350x220	270	0°	270	350x220	270
	45°	240	270x200	170	45°	240	270x200	170	45°	240	270x200	170
	60°	150	150x100	100	60°	150	150x100	100	60°	150	150x100	100
	-45°	210	270x210	180	-45°	210	270x210	180	-45°	210	270x210	180
Ana Motor	1,5 kW				1,5 kW				1,5 kW			
Hidrolik Motor	0,37 kW				0,37 kW				-			
Soğutucu Motor	0,12 kW				0,12 kW				0,12 kW			
Kesme Hızları	20 - 100 m/min				20 - 100 m/min				20 - 100 m/min			
Şerit Testere Ölçüsü	3160x27x0,9 mm				3160x27x0,9 mm				3160x27x0,9 mm			
Malzeme Besleme Yüksekliği	910 mm				910 mm				910 mm			
Ebatlar	Uzunluk 1730 mm Genişlik 770 mm		Yükseklik 1460 mm Ağırlık 525 kg		Uzunluk 1730 mm Genişlik 770 mm		Yükseklik 1460 mm Ağırlık 476 kg		Uzunluk 1730 mm Genişlik 770 mm		Yükseklik 1460 mm Ağırlık 465 kg	

3 Mt Malzeme Sehpa



Hız Kontrol Cihazı



Mikrosprey Soğutucu



BMSY 230 DGH - BMSY 230 DG

Çift Tarafa Açılı Mafsallı Şerit Testere Makinası
DGH - Hidrolik Mengene Standart

Standartlar

Şerit Testere Bıçağı 27
Hız Kontrol Cihazı
Talaş Firçası
Hidromekanik Şerit Germe
Kapak Swich
Mengene
Kumando Panosu
SAP Boryağ Pompası
Planet Redüktör
Yükseklik Ayar Swich
Dayama

Opsiyonel

3 Mt Malzeme Sehpaı
Hız Kontrol Cihazı
Mikrosprey Soğutucu

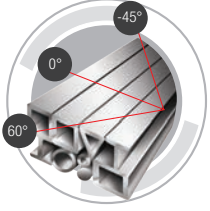

BMSY 230 DGH

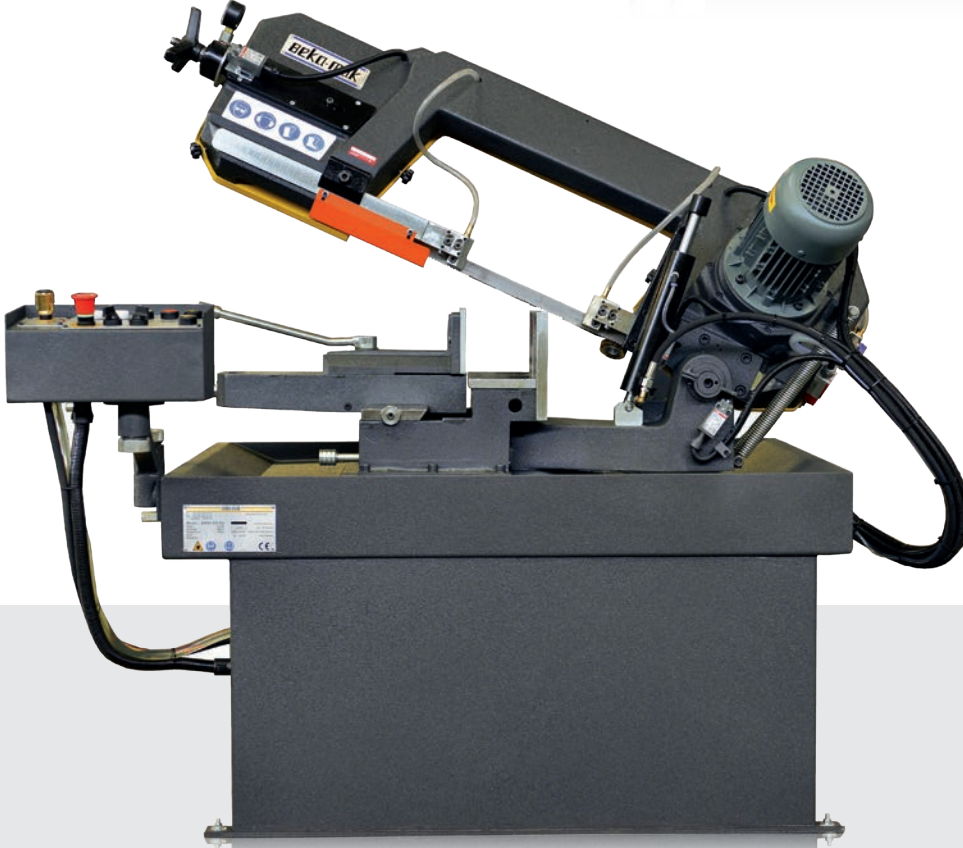

BMSY 230 DG

BMS 230 DG

Çift Tarafa Açılı Mafsallı Şerit Testere Makinası

Standartlar

Şerit Testere Bıçağı 27
Yükseklik Ayar Swich
Hidromekanik Şerit Germe
SAP Boryağ Pompası
Talaş Fırçası
Dayama
Kapak Swich
Kumanda Panosu
Hareketli Mengene

Opsiyonel

3 Mt Malzeme Sehpa
Hız Kontrol Cihazı
Mikrosprey Soğutucu

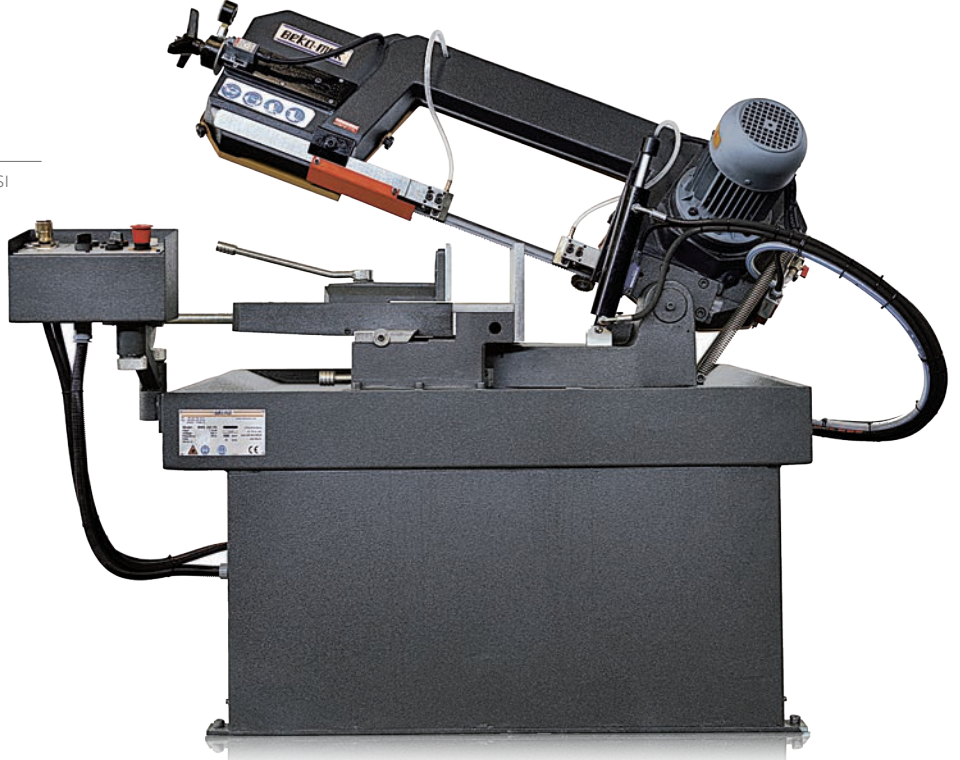
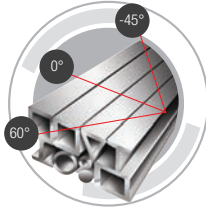

Teknik Özellikler

	BMSY 230 DGH				BMSY 230 DG				BMS 230 DG			
	△	○	□	□	△	○	□	□	△	○	□	□
Kesme Kapasitesi	0°	230	320 x 130	230	0°	230	320 x 130	230	0°	230	320 x 130	230
	-45°	180	230 x 160	150	-45°	180	230 x 100	150	-45°	180	230 x 100	150
	45°	210	230 x 160	180	45°	210	230 x 160	180	45°	120	230 x 160	180
	60°	120	120 x 100	100	60°	120	120 x 100	100	60°	120	120 x 100	100
Ana Motor	1,0 - 1,3 kW				1,0 - 1,3 kW				1,0 - 1,3 kW			
Hidrolik Motor	0,37 kW				0,37 kW				-			
Soğutucu Motor	0,12 kW				0,12 kW				0,12 kW			
Kesme Hızları	35 - 70 m/min				35 - 70 m/min				35 - 70 m/min			
Şerit Testere Ölçüsü	2730 x 27 x 0,9 mm				2730 x 27 x 0,9 mm				2730 x 27 x 0,9 mm			
Malzeme Besleme Yüksekliği	760 mm				760 mm				760 mm			
Ebatlar	Uzunluk 1350 mm Genişlik 700 mm		Yükseklik 1300 mm Ağırlık 465 kg		Uzunluk 1350 mm Genişlik 700 mm		Yükseklik 1300 mm Ağırlık 430 kg		Uzunluk 1350 mm Genişlik 700 mm		Yükseklik 1300 mm Ağırlık 415 kg	

3 Mt Malzeme Sehpa



Hız Kontrol Cihazı



Mikrosprey Soğutucu



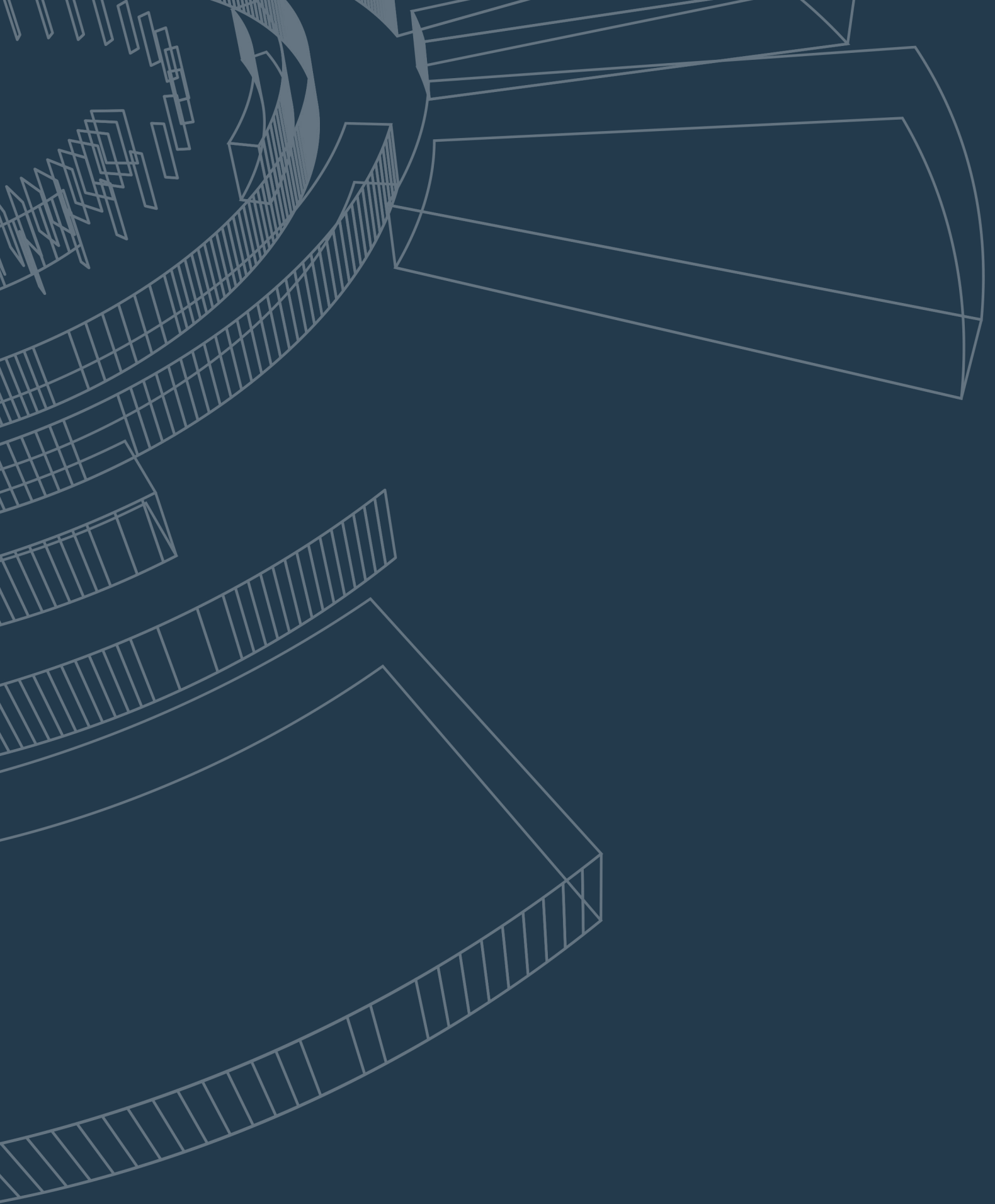

MAFSALLI OTOMATİK ŞERİT TESTERE MAKİNA MODELLERİ

**BMSO 440 - BMSO 320 L
BMSO 320 - BMSO 230**



Model	Sayfa
BMSO 440	100
BMSO 320 L	101
BMSO 320	102
BMSO 230	103

BMSO 440 - BMSO 320 L

Mafsallı Şerit Testere Makinası

Standartlar

Dayama
Vibrasyon Silindir
Talaş Firçası
Sap Boryağ Pompası
Mekanik Üst Baskı
Kapak Swich
Hidrolik Mengene
Hassas Kesim Ayarı

Hidromekanik Şerit Germe
Hız Kontrol Cihazı
Lineer Kızaklı Kol
Şerit Testere Bıçağı 34
1,2 Metre Sehpa
Kontrol Paneli
Yükseklik Ayar Swich

Opsiyonel

Hidrolik Şerit Germe
3 Mt Malzeme Sehpası
Talaş Konveyoru
Mikrosprey Soğutucu
Yükseklik Ayar Sensörü
Hassas Basınç

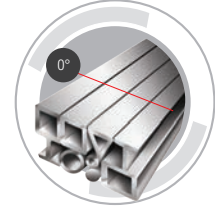

OPSIYONEL

Hidrolik Şerit Germe



3 Mt Malzeme Sehpası



Talaş Konveyoru



Mikrosprey Soğutucu











Hidrolik Mengene



Yükseklik Ayar Sensörü



Teknik Özellikler

	BMSO 440				BMSO 320 L			
								
Kesme Kapasitesi	0°	440	580 x 440	440	0°	330	500 x 320	330
Ana Motor	3 kW				2,2 kW			
Hidrolik Motor	0,55 kW				0,37 kW			
Soğutucu Motor	0,12 kW				0,12 kW			
Sürücü Motor	0,55 kW				0,25 kW			
Talaş Konveyör Motoru	0,25 kW				-			
Kesme Hızları	20 - 100 m/min				20 - 100 m/min			
Şerit Testere Ölçüsü	5200 x 34 x 1,1 mm				4160 x 34 x 1,1 mm			
Malzeme Besleme Yüksekliği	735 mm				640 mm			
Ebatlar	Uzunluk 2630 mm Genişlik 1110 mm		Yükseklik 1710 mm Ağırlık 1140 kg		Uzunluk 2100 mm Genişlik 850 mm		Yükseklik 1300 mm Ağırlık 860 kg	

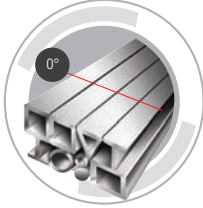

Hassas Basınç



Mikrosprey Soğutucu



Hidrolik Şerit Germe



Talaş Konveyörü



3 Mt Malzeme Sehpa



BMSO 320 - BMSO 230

Tam Otomatik Pivot Tipi Şerit Testere Makinası

Standartlar

Dayama
Hidrolik Mengene(Bms0 320)
Talaş Fırçası
Kontrol Paneli
1,2mt Malzeme Sehpaşı
Mekanik Üst Baskı
Hidromekanik Şerit Germe
SAP Boryağ Pompası

Opsiyonel

Mikrosprey Soğutucu
Hidrolik Şerit Germe
Talaş Konveyör
3 Mt Malzeme Sehpaşı
Hassas Basınç

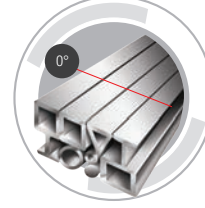

Hassas Basınç



Mikrosprey Soğutucu



Hidrolik Şerit Germe











Talaş Konveyörü



3 Mt Malzeme Sehpaşı



Teknik Özellikler

	BMSO 320				BMSO 230			
								
Kesme Kapasitesi	0°	320	320 x 300	300	0°	230	240 x 230	230
Ana Motor	2,2 kW				1,0 - 1,3 kW			
Hidrolik Motor	0,37 kW				0,37 kW			
Sürücü Motor	0,25 kW				0,25 kW			
Soğutucu Motor	0,12 kW				0,12 kW			
Kesme Hızları	20 - 100 m/min				35 - 70 m/min			
Şerit Testere Ölçüsü	3660 x 27 x 0,9 mm				2730 x 27 x 0,9 mm			
Malzeme Besleme Yüksekliği	640 mm				590 mm			
Ebatlar	Uzunluk 1900 mm		Yükseklik 1350 mm		Uzunluk 1700 mm		Yükseklik 1160 mm	
	Genişlik 850 mm		Ağırlık 770 kg		Genişlik 800 mm		Ağırlık 530 kg	

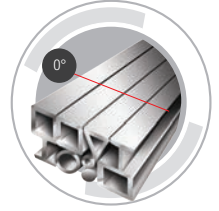
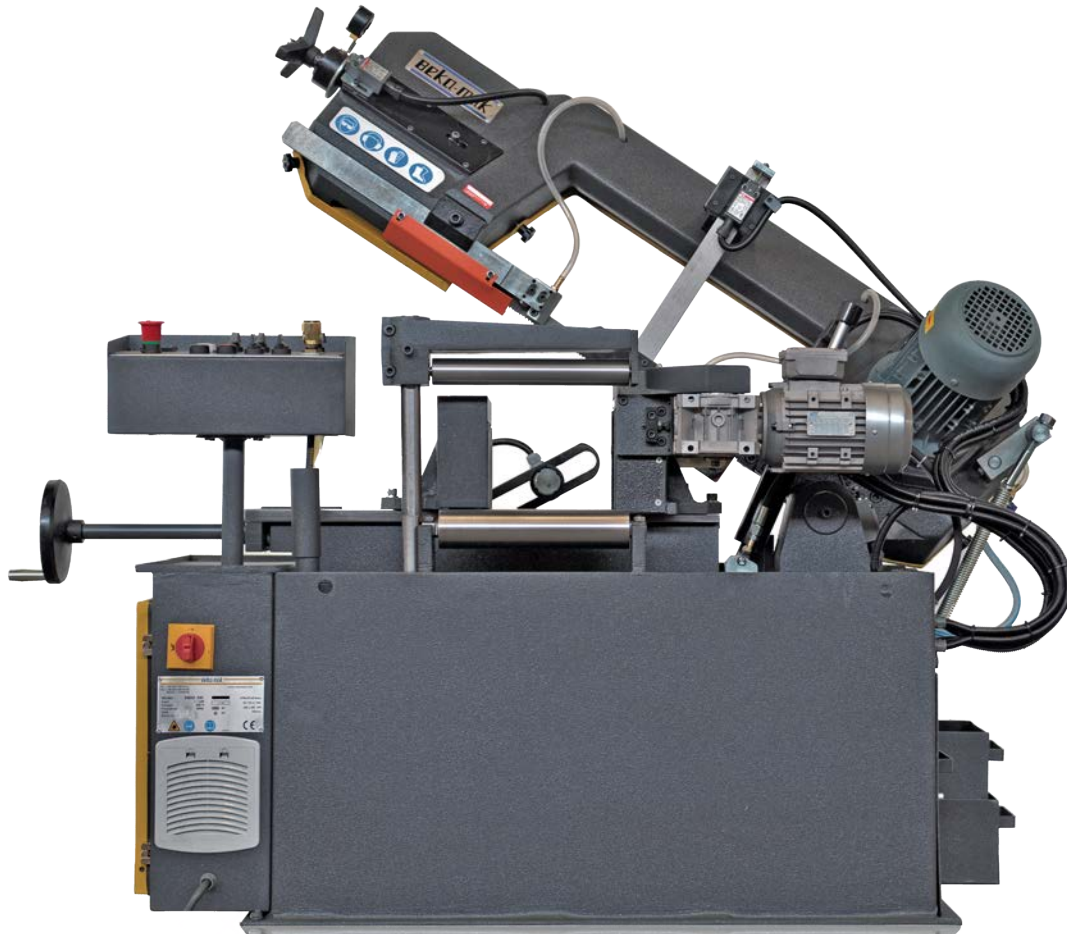

BMSO 230

Mikrosprey Soğutucu



Hız Kontrol Cihazı



3 Mt Malzeme Sehpa



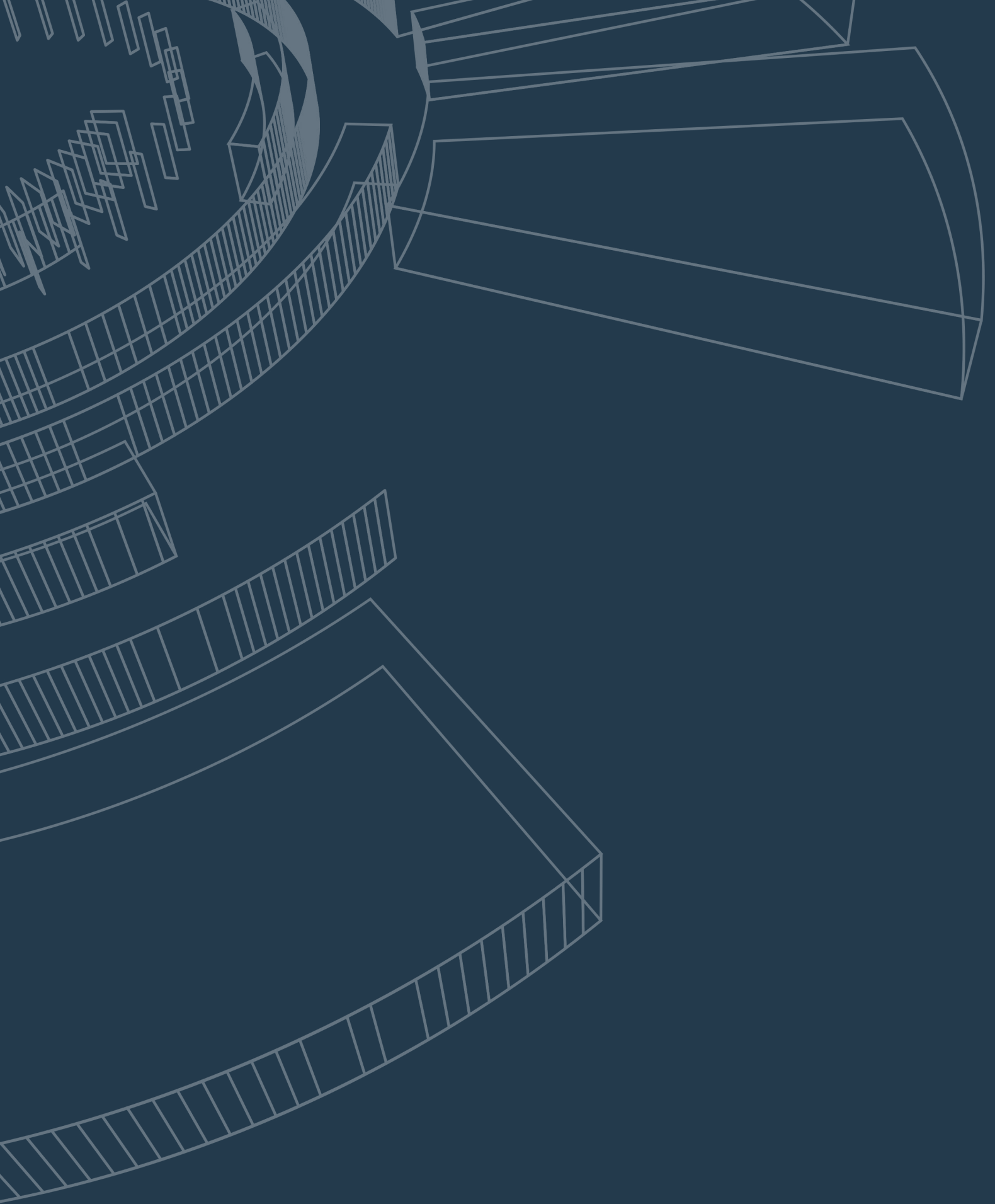

MAFSALLI YARI OTOMATİK ŞERİT TESTERE MAKİNA MODELLERİ

BMSY 440 - BMSY 350 M
BMSY 320 L - BMSY 320
BMSY 280



Model	Sayfa
BMSY 440	106
BMSY 350 M	108
BMSY 320 L	109
BMSY 320	110
BMSY 280	111

BMSY 440

Mafsallı Yarı Otomatik Şerit Testere Makinası

Standartlar

Hız Kontrol Cihazı
Şerit Testere Bıçağı 34
Tekli Sehpa
Dayama
Kapak Swich
Vibrasyon Silindiri
Lineer Kızaklı kol

Planet Redüktör
Hidrolik Mengene
Sap Boryağ Pompası
Hidromekanik Şerit Germe
Kontrol Paneli
Yükseklik Ayar Swich
Talaş Fırçası

Opsiyonel

Hidrolik Şerit Germe
3 Mt Malzeme Sehpa
3 Mt Motorlu Sehpa
Hidrolik Üst Baskı
Talaş Konveyör
Mikrosprey Soğutucu
Döner Tabla



Teknik Özellikler

				
Kesme Kapasitesi	0°	440	610 x 440	440
	45°	410	410 x 440	410
Ana Motor	3 kW			
Hidrolik Motor	0,55 kW			
Soğutucu Motor	0,12 kW			
Talaş Konveyör Motoru	0,25 kW			
? Bow Servo Motor	0,25 kW			
Kesme Hızları	20 - 100 m/min			
Şerit Testere Ölçüsü	5200 x 34 x 1,1 mm			
Malzeme Besleme Yüksekliği	735 mm			
Ebatlar	Uzunluk 2600 mm	Genişlik 900 mm	Yükseklik 1710 mm	Ağırlık 1310 kg

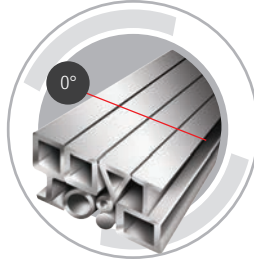

Hidrolik Şerit Germe



3 Mt Malzeme Sehpa



3 Mt Motorlu Sehpa



Hidrolik Üst Baskı



Talaş Konveyörü



Mikrosprey Soğutucu



Döner Tabla



BMSY 350 M - BMSY 320 L

Yarı Otomatik Mafsallı Şerit Testere Makinası

Standartlar

Talaş Fırçası
Kontrol Paneli
Hidromekanik Şerit Germe
Hız Kontrol Cihazı
Yükseklik Ayar Swich
Hidrolik Mengene
Dayama

Tekli Sehpa
Sap Boryağ Pompası
Kapak Swich
Tekli Sehpa

Opsiyonel

ILC Mikrosprey Soğutucu
Hidrolik Şerit Germe
Hassas Basınç
Talaş Konveyör
3 Mt Malzeme Sehpası
Döner Tabla
Hidrolik Üst Baskı

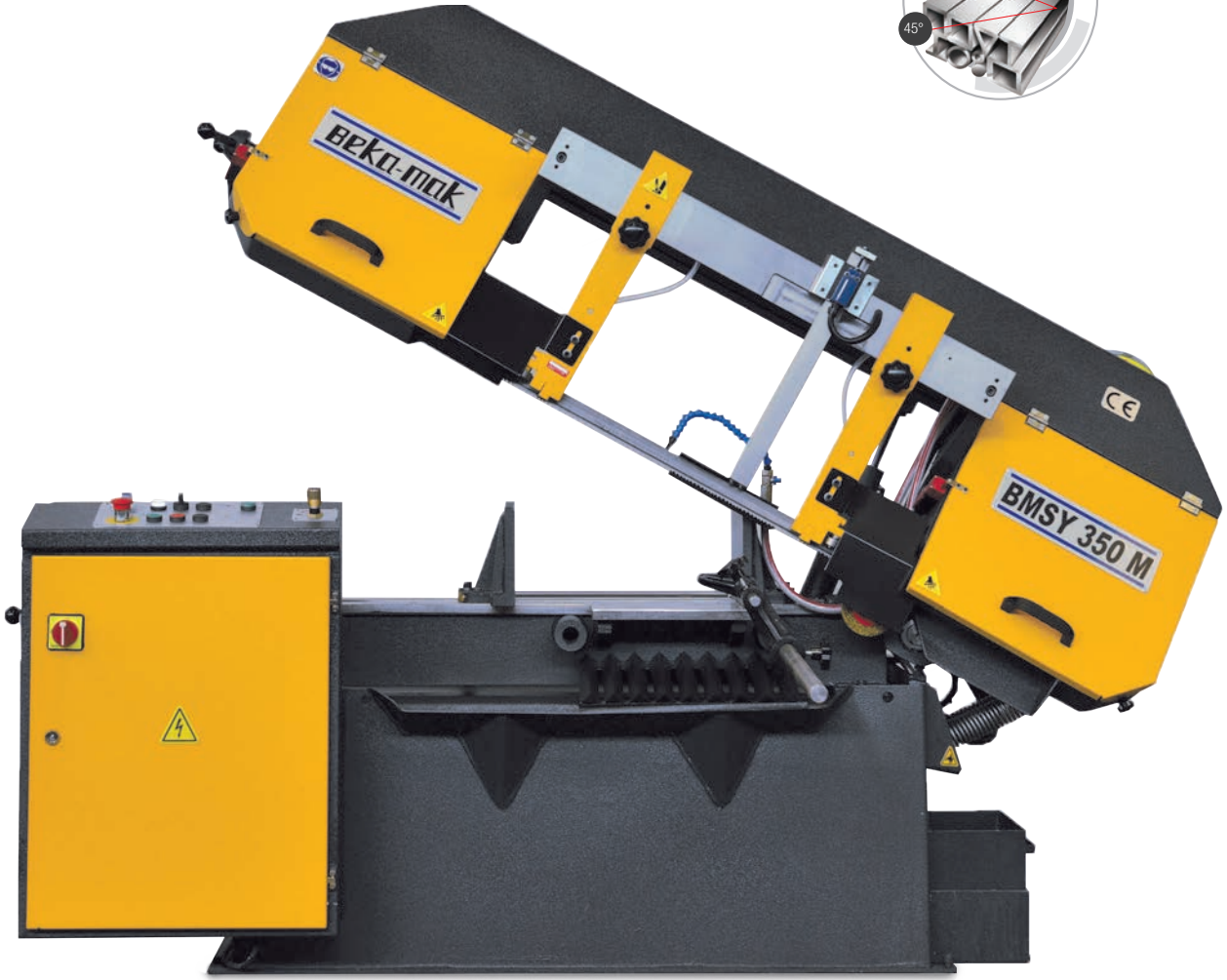
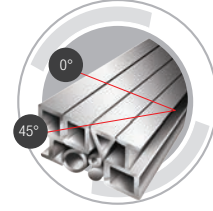

OPSIYONEL

Mikrosprey Soğutucu



Hidrolik Şerit Germe



Hassas Basınç



Talaş Konveyörü



3 Mt Malzeme Sehpası











Döner Tabla



Hidrolik Üst Baskı



Teknik Özellikler

	BMSY 350 M				BMSY 320 L			
								
Kesme Kapasitesi	0°	350	570 x 260	550	0°	330	610 x 310	330
	45°	350	460 x 180	350	45°	320	460 x 180	320
Ana Motor	2,2 kW				2,2 kW			
Hidrolik Motor	0,37 kW				0,37 kW			
Soğutucu Motor	0,12 kW				0,12 kW			
Kesme Hızları	20 - 100 m/min				20 - 100 m/min			
Şerit Testere Ölçüsü	4160 x 34 x 1,1 mm				4160 x 34 x 1,1 mm			
Malzeme Besleme Yüksekliği	640 mm				640 mm			
Ebatlar	Uzunluk 2300 mm		Yükseklik 1300 mm		Uzunluk 2100 mm		Yükseklik 1300 mm	
	Genişlik 850 mm		Ağırlık 795 kg		Genişlik 850 mm		Ağırlık 773 kg	

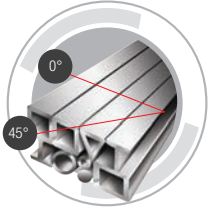

BMSY 320 - BMSY 280

Yarı Otomatik Mafsallı Şerit Testere Makinası

Standards

Mengene
Dayama
Yükseklik Ayarlama
Elektrik Panosu

Optionals

Hidrolik Üst Baskı
Mikrosprey Soğutucu
Hassas Basınç
Talaş Konveyör
3 Mt Malzeme Sehpa
Döner Tabla
Hidrolik Şerit Germe

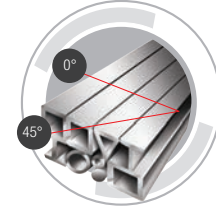

Hidrolik Üst Baskı



Mikrosprey Soğutucu



Hassas Basınç



Talaş Konveyörü



3 Mt Malzeme Sehpa











Döner Tabla



Hidrolik Şerit Germe



Teknik Özellikler

	BMSY 320				BMSY 280			
								
Kesme Kapasitesi	0°	320	440 x 220	320	0°	280	350 x 200	280
	45°	280	280 x 200	260	45°	240	240 x 180	210
Ana Motor	1,5 kW				1,5 kW			
Hidrolik Motor	0,37 kW				0,37 kW			
Soğutucu Motor	0,12 kW				0,12 kW			
Kesme Hızları	20 - 100 m/min				20 - 100 m/min			
Şerit Testere Ölçüsü	3660 x 27 x 0,9 mm				3400 x 27 x 0,9 mm			
Malzeme Besleme Yüksekliği	640 mm				640 mm			
Ebatlar	Uzunluk 1900 mm Genişlik 850 mm		Yükseklik 1300 mm Ağırlık 670 kg		Uzunluk 1800 mm Genişlik 850 mm		Yükseklik 1300 mm Ağırlık 620 kg	

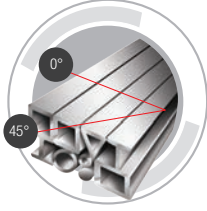

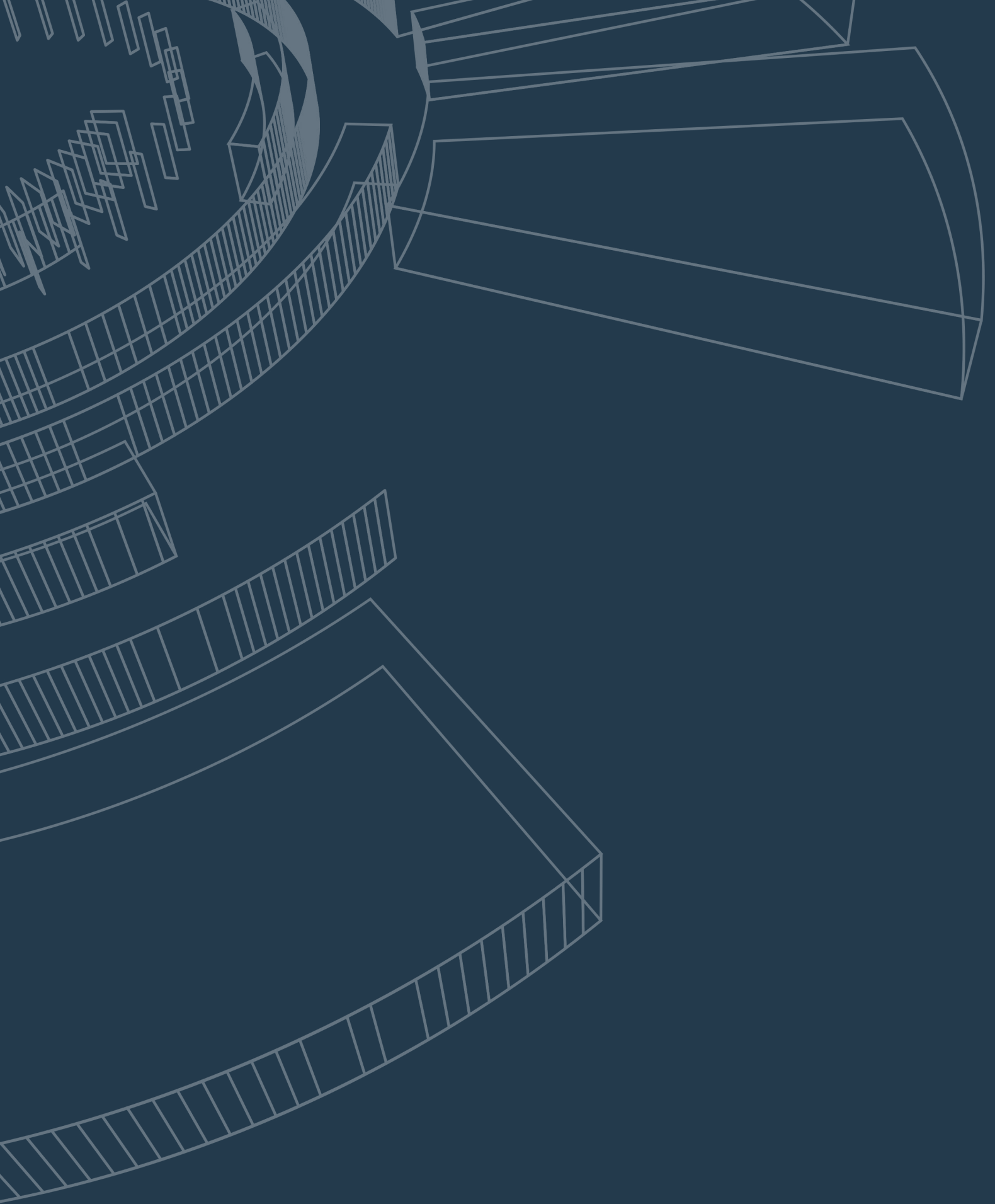

MAFSALLI MANUEL ŞERİT TESTERE MAKİNA MODELLERİ

BMS 320 - BMS 280

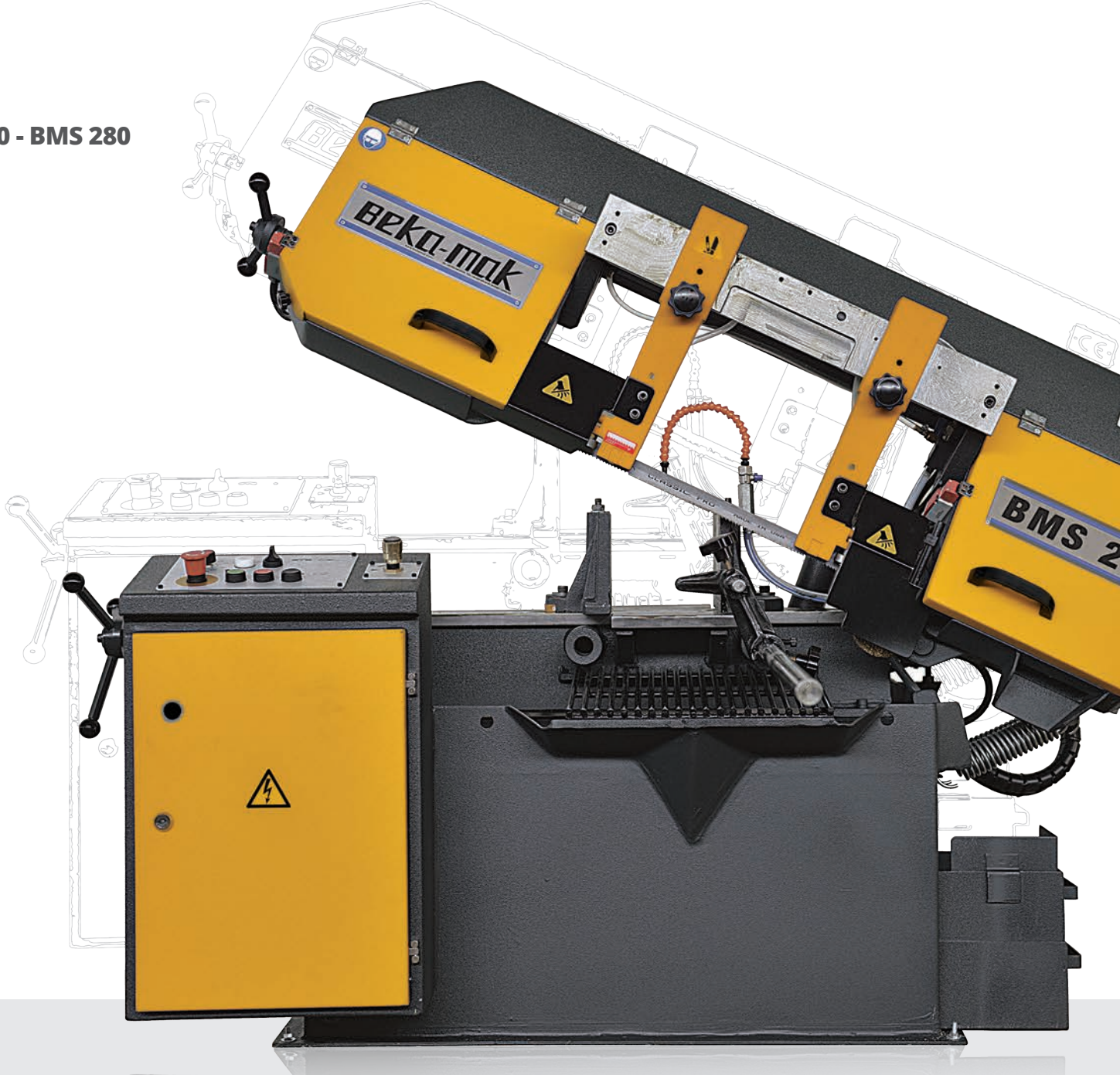

Model	Sayfa
BMS 320	114
BMS 280	115

BMS 320 - BMS 280

Mafsallı Manuel Şerit Testere Makinası

Standartlar

Talaş Firçası
Şerit Testere Bıçağı 27
Kumando Paneli
Dayama

Kapak Swich
Hız Kontrol Cihazı
Hidromekanik Şerit Germe
SAP Boryağ Pompası

Opsiyonel

Microspray Coolant
3 Mt Roller Table
Chip Conveyor
Turn Table

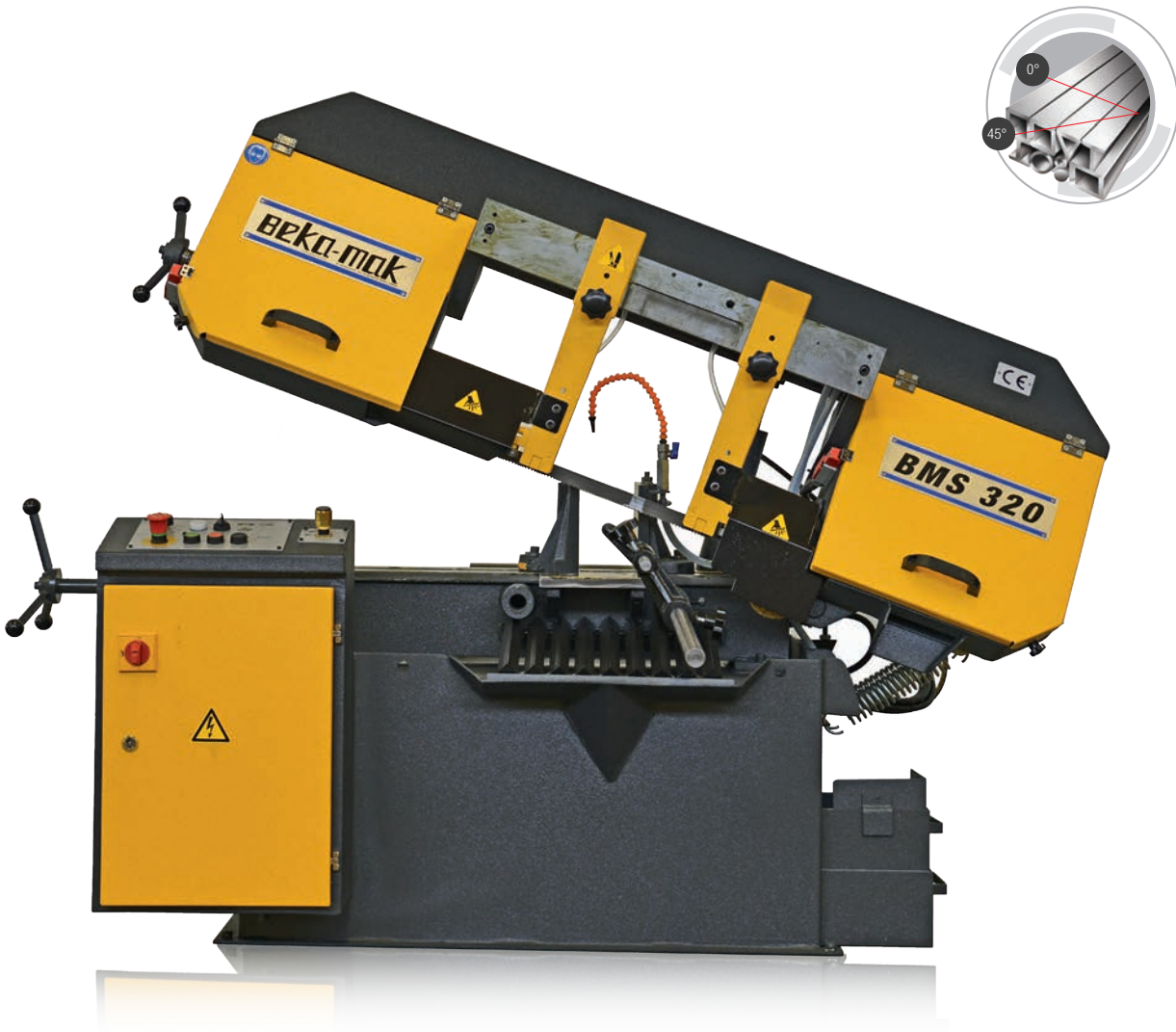

Mikrosprey Soğutucu



3 Mt Malzeme Sehpaı











Talaş Konveyör



Döner Tabla



Teknik Özellikler

	BMS 320				BMS 280			
Kesme Kapasitesi								
	0°	320	440 x 220	320	0°	280	350 x 200	280
	45°	280	280 x 200	260	45°	240	240 x 180	210
Ana Motor	1,5 kW				1,5 kW			
Soğutucu Motor	0,12 kW				0,12 kW			
Kesme Hızları	20 - 100 m/min				20 - 100 m/min			
Şerit Testere Ölçüsü	3660 x 27 x 0,9 mm				3400 x 27 x 0,9 mm			
Malzeme Besleme Yüksekliği	640 mm				640 mm			
Ebatlar	Uzunluk 1900 mm		Yükseklik 1300 mm		Uzunluk 1800 mm		Yükseklik 1300 mm	
	Genişlik 850 mm		Ağırlık 625 kg		Genişlik 850 mm		Ağırlık 595 kg	

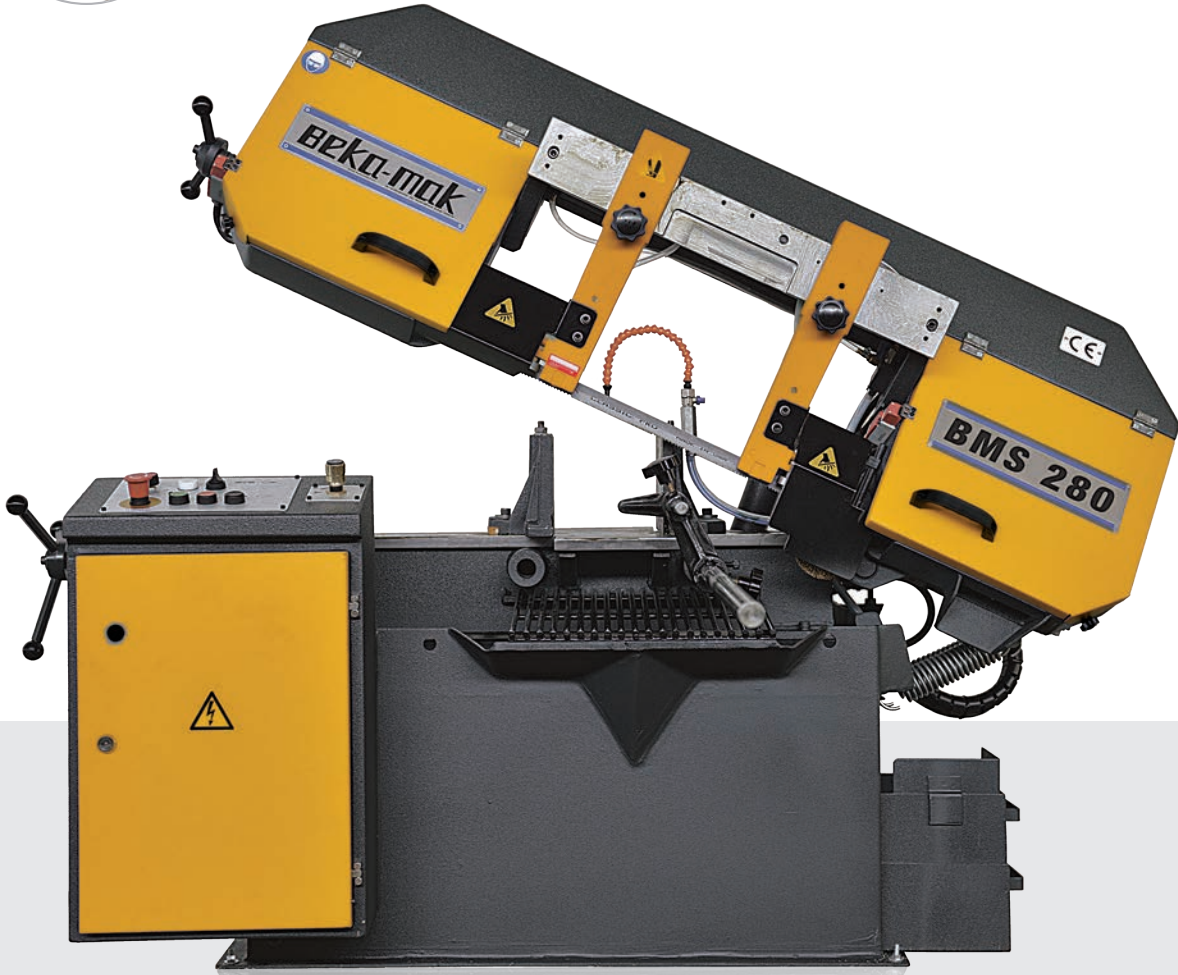
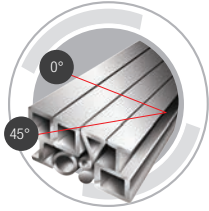

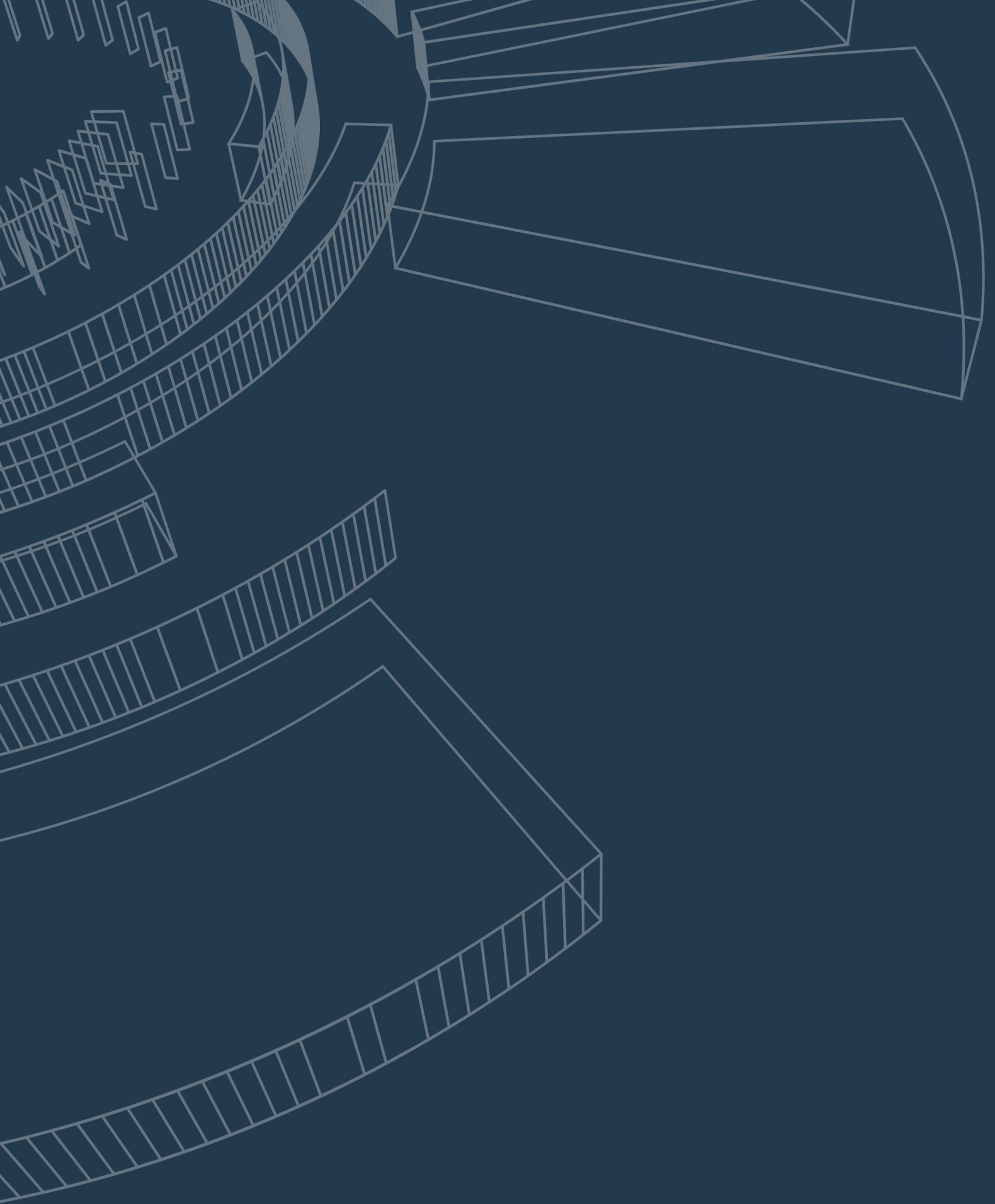





BMH 170

Hidrolik Kollu Testere Makinası

Standartlar

Basınç Ayarı
Boryağ Sprali
Elektrik Panosu
Kumanda Panosu
Mengene
Silindir
Soğutucu Pompa
Testere Bıçağı
Yan Sehpa
Yükseklik Ayarı

Teknik Özellikler

				
Kesme Kapasitesi	0°	170	200 x 120	145
	45°	110	110 x 110	120
Ana Motor	0,75 kW			
Kesme Hızları	120 m/min			
Şerit Testere Ölçüsü	350 x 30 x 1,5 mm			
Malzeme Besleme Yüksekliği	430 mm			
Ebatlar	Uzunluk 1100 mm Genişlik 600 mm		Yükseklik 810 mm Ağırlık 265 kg	



Makaralı Masa



TUBES

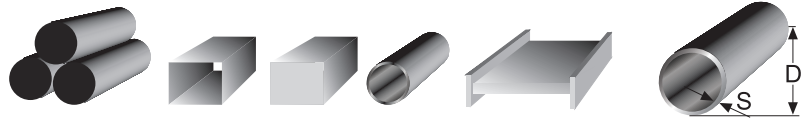

WALL THICKNESS s(mm)	Outside Diameter D(mm) Tothing Z (tpi)									
	20	40	60	80	100	120	150	200	300	500
2	14	10/4	10/4	10/4	10/4	8/12	8/12	8/12	8/12	5/8
3	14	10/4	10/4	8/12	8/12	8/12	8/12	6/10	6/10	5/8
4	10/4	10/4	8/12	8/12	8/12	6/10	6/10	5/8	5/8	4/6S
5	10/4	10/4	8/12	8/12	6/10	6/10	5/8	4/6S	4/6S	4/6S
6	10/4	8/12	8/12	6/10	6/10	5/8	5/8	4/6S	4/6S	4/6S
8	10/4	8/12	8/12	6/10	5/8	5/8	4/6	4/6	4/6	4/6
10		8/12	6/10	5/8	4/6	4/6	4/6	4/6	4/6	4/5
12		8/12	6/10	4/6	4/6	4/6	4/6	4/6	4/6	4/5
15		8/12	6/10	4/6	4/6	4/6	4/6	4/5	4/5	4/5
20			4/6	4/6	4/6	4/6	4/6	4/5	4/5	3/4
30				4/6	4/6	4/5	4/5	4/5	4/5	2/3
50							4/5	3/4	2/3	2/3
80								3/4	2/3	2/3
>100									2/3	1,5/2

SOLID MATERIAL

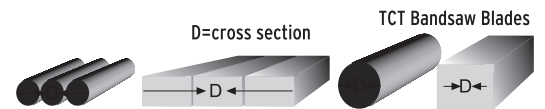

Standart Tothing		Vario Tothing		Vario Tothing	
Cross Section	Tothing	Cross Section	Tothing	Cross Section	Tothing
bis 10 mm	14 tpi	bis 25 mm	10/14 tpi	50-120 mm	3/4 tpi
10-30 mm	10 tpi	15-40 mm	8/12 tpi	100-250 mm	2/3 tpi
30-50 mm	8 tpi	25-20 mm	6/10 tpi	150-400 mm	1.5/2 tpi
50-80 mm	6 tpi "	35-70 mm	5/8 tpi	350-600 mm	1.1/1.6 tpi
80-120 mm	4 tpi **	40-90 mm	5/6 tpi	>500 mm	0.75/1.25 tpi
120-200 mm	3 tpi **	50-120 mm	4/6 tpi***		
200-400 mm	2 tpi	80-180 mm	3/4 tpi***		
300-700 mm	1.25 tpi	130-135 mm	2/3 tpi		
>600 mm	0,75 tpi	150-450 mm	1.5/2 tpi		
		200-600 mm	1.1/1.6 tpi		
		>500 mm	0.75/1.25 tpi		

Hidrolik Üst Baskı
BMSY 1110 C



Hidrolik Üst Baskı
NC Makinalar



MALZEME SEHPASI BMSY 650 DG



Lazer İşaretleyici



Miko Püskürtme



3MT MOTORLU MALZEME SEHPASI BMSY 440DGH



Demet Kesim Çeneleri

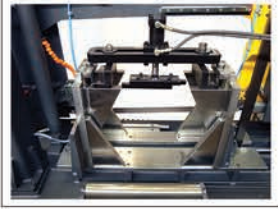

Demet Kesim Çeneleri



Hidrolik Üst Baskı



Hidrolik Şerit Germe

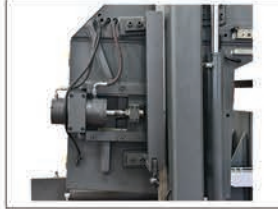

3MT MOTORLU MALZEME SEHPASI BMSY 820C



Talaş Konveyoru
BMSY 1110 C



Talaş Konveyoru
BMSY 650 DG



3 MT MALZEME SEHPASI FOR BMSY 810C



Çift Mengene BMSY 1110 C



Talaş Konveyoru
BMSO 360 CH

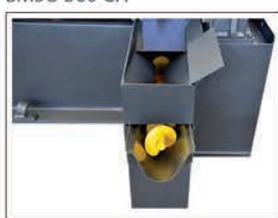



A series of horizontal dashed lines for writing or drawing.

A series of horizontal dashed lines for writing or drawing.

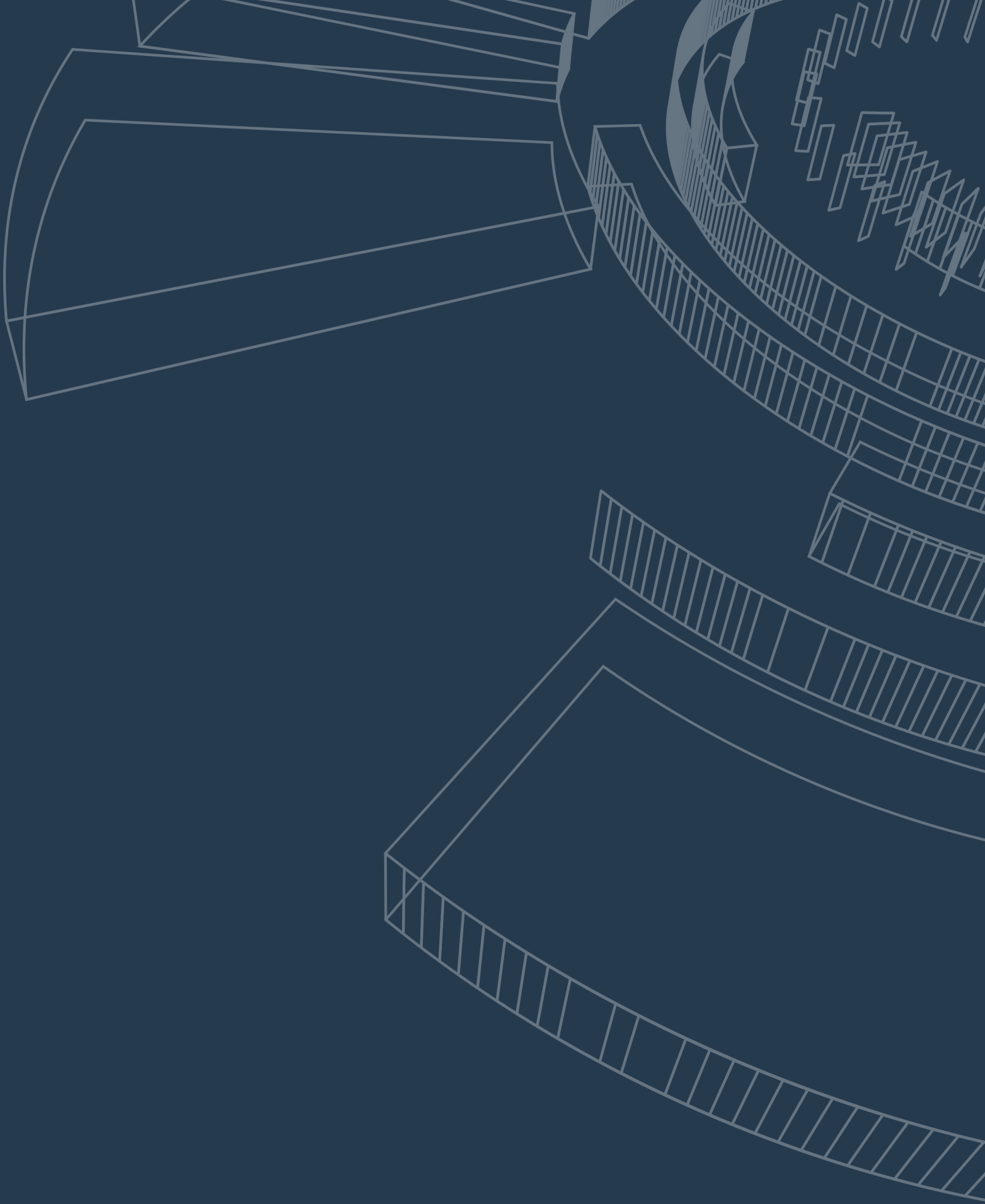

BEKA-MAK®

şerit testere makineleri

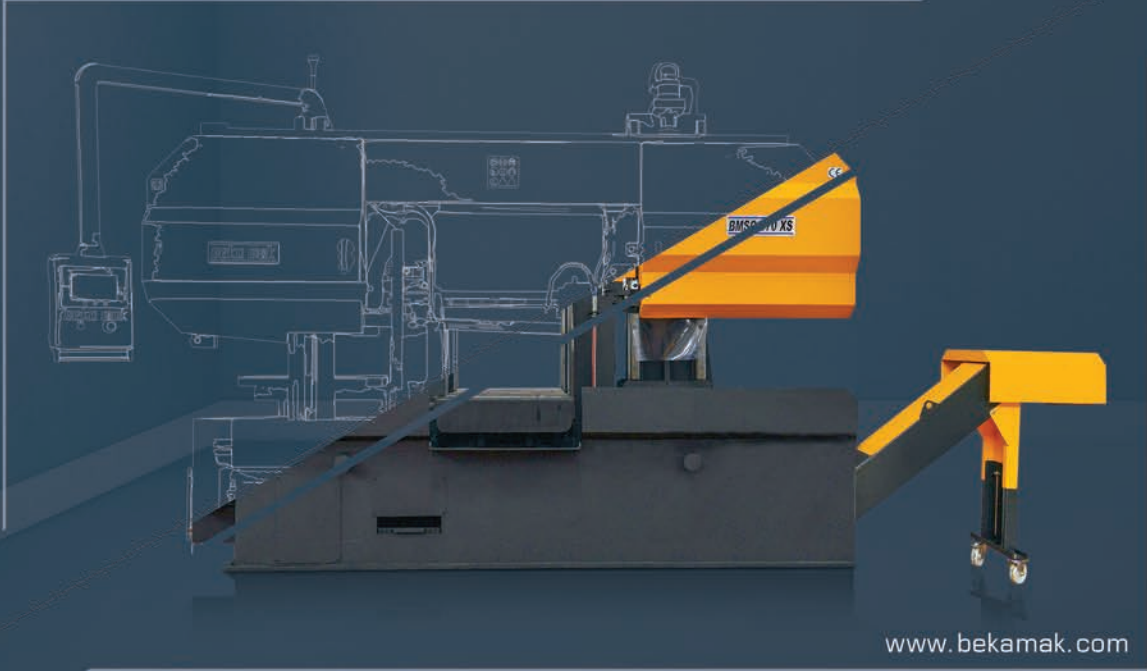

www.bekamak.com

BEKA - MAK MAKİNE SANAYİ VE TİCARET A.Ş.

Başköy İzmir Yolu Cad. No: 698 16370 Nilüfer / BURSA

Tel : +90 (224) 449 03 61

Fax : +90 (224) 449 03 60

E-mail : info@bekamak.com



MEMBER OF



Türkiye Makina
İmalatçılar Birliği
www.mib.org.tr



European Committee for
Cooperation of the Machine Tool Industries
www.cecimo.be



BEKA - MAK BAYII

